

Chapter 8 Geological Hazards in the Project Area

8.1 INTRODUCTION

The geohazards are: general seismicity/ground shaking; active faults; liquefaction; and mass wasting and slope instability. Design of the various facilities is based on detailed evaluations of each of these hazards which have been carried out by Russian and International Experts. The reports on these evaluations and studies provide the input parameters for design.

8.2 TECTONIC SETTING

Sakhalin Island is located along a diffuse plate boundary zone between the Eurasian tectonic plate and either the North American tectonic plate, or the Okhotsk microplate (EQE, 1996a; Figure 8.1). While the eastern plate boundary in this region is accepted to be the Kuril trench that extends northeastward from offshore of eastern Hokkaido, the exact configuration of a plate boundary to the north of the Sea of Okhotsk is not clearly resolved. This is due primarily to the fact that relative plate motions and associated tectonic deformation in this region are quite low, and because relative plate motions inferred from earthquake slip vectors along the Japan and Kuril trenches are consistent with either plate tectonic interpretation. Nonetheless, regardless of which model might be correct, both interpretations define the western boundary of the tectonic plate as a zone of north-trending transpressional shear that extends through Sakhalin Island southward into the western region of Hokkaido.

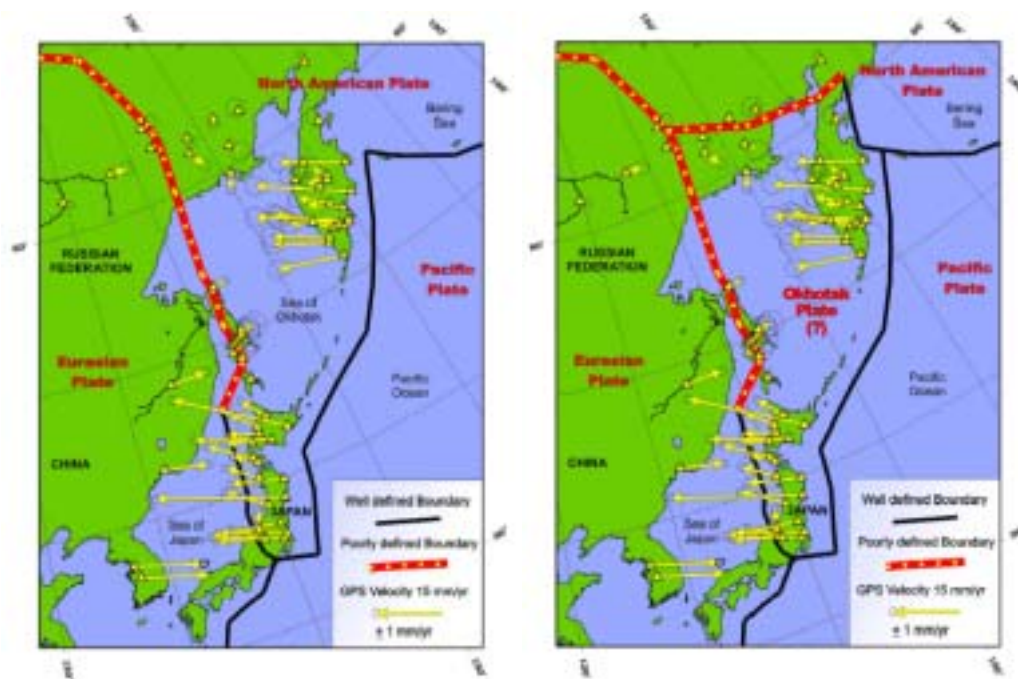

Figure 8.1. Alternative models of the plate tectonic setting of northeastern Asia showing well defined and poorly defined plate boundaries and available local GPS velocity data (from Apel et al., 2004).

Large thrust earthquakes have occurred in the eastern Japan Sea, offshore of western Hokkaido (Figure 8.2). This offshore zone of thrust faulting has been attributed to sea-floor spreading in the Japan Sea that results in tectonic compression and thrust faulting along the western Hokkaido margin (Jolivet et al., 1994). The zone of thrust faulting extends northward along the western margin of southern Sakhalin Island where several moderate thrust earthquakes have occurred in the past. The 1924 Lesogorsk-Uglegorsk (M_{LH} 7.0), 1971 Moneron (M_{LH} 7.5) and the 2000 Uglegorsk (M_{LH} 6.8) earthquakes all occurred in this region and exhibited thrust movement on generally north-trending fault planes. The principal horizontal tectonic stress axis is approximately N 70° E in the central and southern part of the island based on paleostress investigations of faults, observed Quaternary fault offsets, and focal mechanisms of recent earthquakes. This compressive tectonic stress direction is consistent with plate tectonic models indicating transpressional compressive stress throughout the Island.

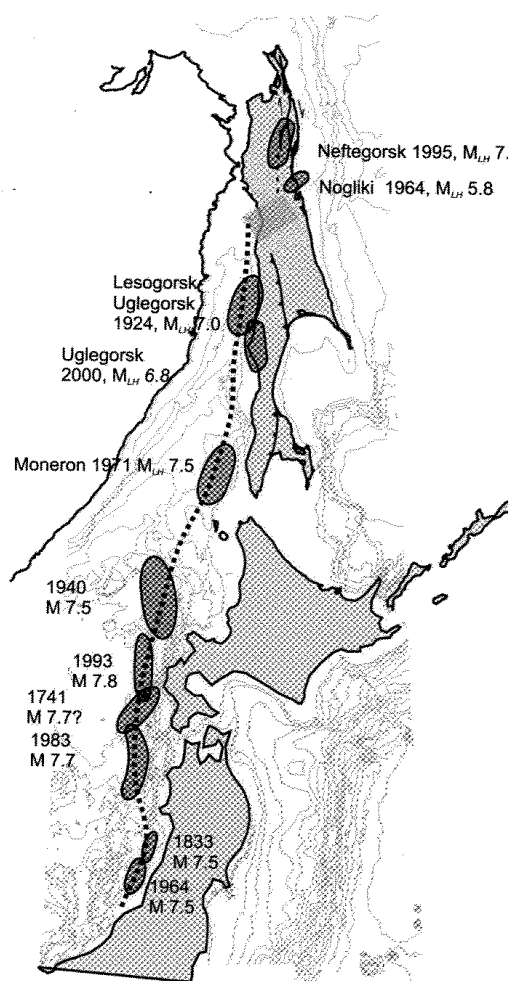

Figure 8.2. Rupture locations of significant earthquakes occurring along the eastern margin of the Japan Sea off the western coasts of Honshu and Hokkaido, along the eastern margin of the Tartar Strait off the western coast of southern and central Sakhalin Island, and along the northeastern coast of Sakhalin Island.

Dominant faulting styles are different between the northern, and the central and southern parts of the island (EQE, 1996a; Figure 8.3). Whereas thrust faulting dominates the central and southern regions, strike-slip faulting on north-northeast trending faults dominates the tectonic style of the northern part of the island. The differences in tectonic style are reflected by the relatively subdued topography of northern Sakhalin compared to the rugged topography of southern Sakhalin. The significant strike-slip earthquakes of northern Sakhalin the 1964 Nogliki (M_{LH} 5.8) and the 1995 Neftegorsk (M_{LH} 7.2) earthquakes. Whereas the significant thrust earthquakes to the south all have occurred near the western margin of the island, the strike-slip earthquakes in the north have occurred along the eastern margin of the island. The change in structural style has been inferred to occur along a poorly defined northeast-trending zone at about 52° N. Coincident with the change in structural style, the regional compressive stress rotates

counterclockwise to a north-northeasterly trend above 52°N compared to the east-northeast trend south of 52°N (EQE 2000).

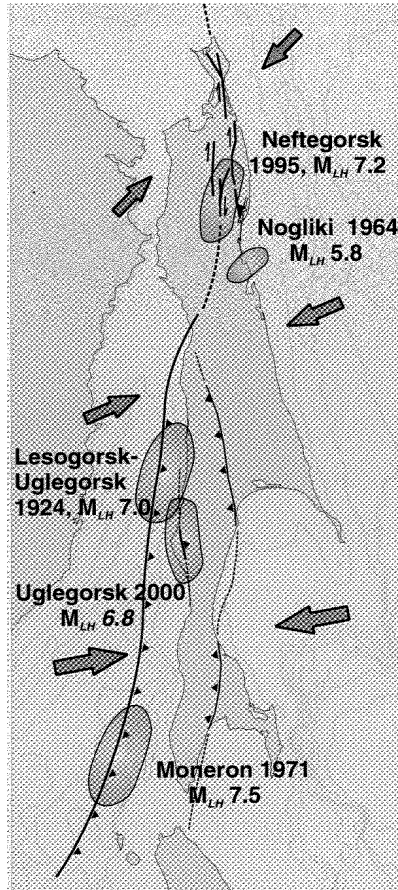

Figure 8.3. Rupture areas of significant Sakhalin earthquakes shown in relation to the style of faulting and azimuth of the regional compressive stress tensor. Bold lines in northeastern Sakhalin show the locations of the Piltun-Goromai and Upper Piltun strike-slip and strike-slip oblique faults. Bold line with barbs shows the general location of the thrust front at the eastern margin of the West Sakhalin Mountains in central and southern Sakhalin.

The structural deformation styles and GPS data of Sakhalin Island corresponds rather well with that predicted by the plate tectonic models of Seno (1995) and Seno et al. (1996). These models recognizes the Okhotsk microplate and places the pole of rotation between it and the Eurasian plate near the west coast of northern Sakhalin Island near 52° N (Figure 8.4).

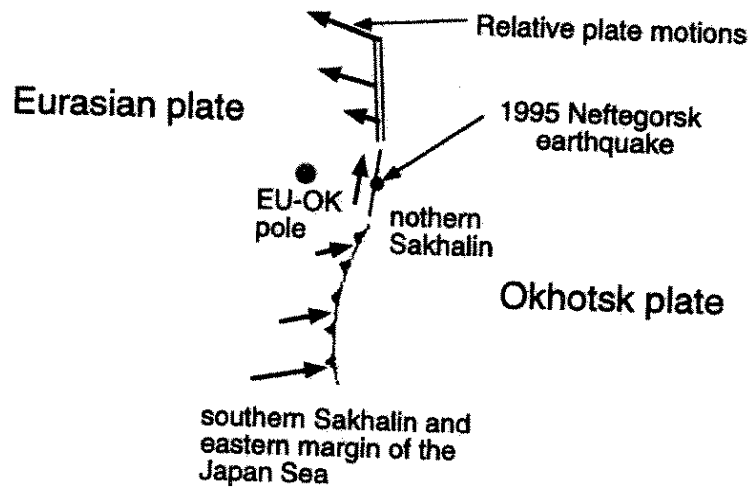

Figure 8.4. Plate tectonic model for the Okhotsk microplate showing the calculated pole of rotation and the predicted faulting styles north and south, of the pole of rotation (Seno, 1995; Seno et al., 1996).

8.3 HISTORICAL SEISMICITY

The earthquake history of Sakhalin Island dates from the first reported earthquake in 1905 (EQE, 1996a). Earthquakes smaller than $M_{LH} \geq 5.5$ are broadly scattered in the vicinity of Sakhalin and exhibit loosely clustered trends of epicenters in the western region of the southern half of the island and in the eastern region of the northern half of the island (EQE, 1996a). Earthquakes of $M_{LH} \geq 6.0$ have occurred at depths greater than 250 km at the southern extremity of the island (EQE, 1996a). These deep earthquakes have not caused damage at the surface. A cluster of shallow focus earthquakes occurs off the western coast of the island in the vicinity of the Okhotsk –Eurasia plate boundary (Figure 8.3). These earthquakes include the 1924 Lesogorsk-Ulegorsk (M_{LH} 7.0), 1971 Moneron (M_{LH} 7.5) and the 2000 Ulegorsk (M_{LH} 6.8) earthquakes. The 1995 Neftegorsk (M_{LH} 7.2) and the 1964 Nogliki (M_{LH} 5.8) earthquakes define a loose concentration of shallow focus earthquake activity along the eastern margin of the island north of 52° N. Brief descriptions of some of the better-studied significant earthquakes of Sakhalin Island are given below.

8.3.1 27 May 1995 Neftegorsk Earthquake

The 27 May 1995 Neftegorsk earthquake (M_{LH} 7.2) that occurred in northeastern Sakhalin is the largest earthquake to have occurred on Sakhalin Island (EQE, 1996a). Over 2,000 people were killed in Neftegorsk when multi-story apartment buildings collapsed. The earthquake ruptured a 37-km segment of the Upper Piltunsky fault that strikes generally N 15° E along the main rupture segment. The primary displacement on the fault was right-lateral strike-slip with a lesser amount of vertical movement (Shimamoto et al., 1996). The northern end of the surface rupture terminated about 3 km southeast of the town of Neftegorsk.

8.3.2 4 August 2000 Ulegorsk Earthquake

The 4 August Ulegorsk earthquake (M_{LH} 6.8) occurred near the western coast of Sakhalin Island at latitude 48.8° N. No direct deaths were reported from this earthquake although there was considerable damage to common construction in the earthquake area. Surface rupture striking 350° occurred along a 5-km fault segment at the base of the eastern slope of Mount Krasnov and exhibited 0.8 m of reverse vertical displacement and no lateral displacement.

8.3.3 2 October 1964 Nogliki Earthquake

Despite its moderate size, the 2 October 1964 Nogliki (M_{LH} 5.8) earthquake caused considerable damage in eastern Sakhalin Island. The intensity level of this earthquake was rated MSK 8-9 by Oskorbin et al. (1967), which is a shaking level sufficiently high to cause significant damage to unreinforced masonry construction. The high intensity level for this moderate earthquake has been ascribed to its shallow focus (< 10 km) and the presence of widespread soft soil conditions in the immediate epicentral area (Oskorbin et al., 1967).

8.3.4 5 September 1971 Moneron Earthquake

The 1971 Moneron (M_{LH} 7.5) earthquake occurred along the eastern margin of the Tartar Strait, off of the southwestern coast of Sakhalin near Moneron Island. MSK intensity values of 7 to 8 were reported on Moneron (Solov'yev et al., 1973). Damage was greatest on Sakhalin Island in the mining villages of Shebunino and Gornozavodsk along the southwestern coast of the island. Damage was generally confined to older buildings of small-dimension solid unit masonry. Newer buildings made of "panels" and "large blocks" reportedly withstood the earthquake well. A 2 m high tsunami was reported at Shebunino and Gornozavodsk while flooding on the coast of Moneron Island was reported at 1.5 m. Reports of tsunami heights elsewhere were less than 1 m. A focal mechanism of the earthquake (Solov'yev et al., 1973) indicated that the earthquake was caused by reverse faulting on a north-striking fault plane dipping 72.5° E.

8.3.5 15 March 1924 Lesogorsk-Ulegorsk Earthquakes

Little is recorded in the literature regarding this earthquake because of its antiquity and its occurrence offshore of the lightly populated central west coast of Sakhalin Island. The 1924 M_{LH} 7.0 Lesogorsk-Ulegorsk earthquake occurred along the eastern margin of the Tartar Strait along the northern extension of the same thrust belt that generated the 1971 M_{LH} 7.5 Moneron earthquake. This belt of thrust faulting extends northward from western Hokkaido and has been associated with a number of large earthquakes in Japan.

8.4 GEOLOGY AND STRUCTURE

8.4.1 Stratigraphy

The regional stratigraphy of Sakhalin Island is organized around three primary structural and geological provinces (Fournier et al., 1994; Intera, 1991). These are the rugged West and East Sakhalin Mountains in the central part of the Island south of 52° N and the topographically subdued northern Island region, north of about 52° N (Figure 8.5). In the southern part of the Island, east of Yuzhno-Sakhalinsk, basement rocks of the Susunai Metamorphic complex are equivalent in age to those of the East Sakhalin Mountains. South of Terpeniya Bay, the Susunai Depression of the southern Island separates the Susunai Metamorphic complex from the West Sakhalin Mountains in a manner analogous to the Central Sakhalin Depression in the central part of the Island.



Figure 8.5. Morpho-stratigraphic regions of Sakhalin Island.

The oldest rocks on Sakhalin are found in the East Sakhalin Mountains and the Susunai Metamorphic complex (Figure 8.5). These rocks are composed of Paleozoic basement materials that were metamorphosed under high temperature/low pressure conditions in Triassic time and intruded by plutonic rocks of early Jurassic age. These basement rocks are overlain by sequences of Cretaceous-Paleogene age basalts, cherts and shales suggesting an origin associated with the accretionary prism complex of a west-dipping subduction zone located off the eastern coast of the Island (Ben-Avraham and Uyeda, 1983).

Metamorphic rocks of the East Sakhalin Mountains dip westward beneath the Neogene and Quaternary sediments of the Central Sakhalin Depression (Figure 8.5; Fournier et al., 1994). The Central Sakhalin Depression forms the axial valley of the Island to north and south of Terpenya Bay, but loses its structural expression in the northern region of the Island where topographic relief is subdued.

Neogene sediments of the Central Sakhalin Depression are overthrust by thick, highly folded Cretaceous sedimentary rocks of the West Sakhalin Mountains. Two significant thrust faults occupy the structural boundary zone at the western margin of the Central Sakhalin Depression. The Tym-Poronaysk fault is a west-dipping regional thrust fault that structurally juxtaposes Cretaceous rocks of the West Sakhalin Mountains over Neogene sediments of the Central Sakhalin Depression (Fournier et al., 1994). The Kliuchevskoi thrust fault is located to the east of the Tym-Poronaysk fault and structurally juxtaposes Neogene sediments of the western valley over Quaternary sediments. The Kliuchevskoi fault is the younger of the two faults and of primary importance to Sakhalin II export pipeline.

Cretaceous rocks of the West Sakhalin Mountains rest unconformably over Paleozoic – Mesozoic basement rocks (Fournier et al., 1994). Westward through the West Sakhalin Mountains, a Neogene sequence of terrigenous and volcanogenic sediments lies unconformably over the folded Cretaceous section.

North of about 52° N, Cretaceous and older rocks are mostly absent at the surface and the region is covered by thick Cenozoic terrigenous sediments (Intera, 1991). Topographic relief of this area is considerably more subdued than in the central and southern regions of the island and large areas of thick Plio-Quaternary sedimentation occupy low-lying coastal areas, particularly along the Strait of Tartar coast.

The Quaternary period represents a continuation of Neogene geological activity on Sakhalin Island. In addition to passive Quaternary sedimentation in the valleys and along coastal areas, the West Sakhalin Mountains continue to actively uplift and thrust over the sediments of the Central Sakhalin Depression (Fournier et al., 1994). Evidence of this continuing tectonic activity is preserved in the young Quaternary sediments in some areas and includes scarps on Quaternary alluvium from surface fault offsets and flights of stream terraces that record repeated uplift of valley floors and subsequent regrading of stream profiles (ABSC 2005).

8.4.2 Active Faults

Active geological structures in the Quaternary Period are concentrated within the eastern coastal region of northern Sakhalin, along the western margin of the Central Sakhalin Depression at its structural contact with the West Sakhalin Mountains, and in the near-coastal region of the Tartar Strait coast south of about 52° N (Bulgakov et al., 2002). Based on investigations of active faults (Bulgakov et al., 2002) and plate motions (Seno, 1995), movements on faults in northeastern Sakhalin are predominantly right-lateral strike-slip as opposed to predominantly reverse or thrust movements that occur on the active faults in central and southern Sakhalin.

8.4.2.1 Northeastern Sakhalin Island

The project facilities in relation to the active faults in Northeast Sakhalin are shown on Map 1. Active faults of primary concern in Northeastern Sakhalin are the Piltun-Goromai, and Upper Piltun faults. The Piltun fault extends 42 km north from the Poronai River to the northern Piltun Bay and exhibits right-lateral displacement of surface features and stream crossings (Bulgakov et al., 2002; Figure 8.6).

South of the Poronai River, the Goromai Fault is on-strike with the Piltun Fault to the north and displays a minor thrust component of movement in shallow soils (Bulgakov et al., 2002), which is likely related to a slight change in fault strike within the uniform transpressional tectonic stress regime (ABS Consulting, 2005).

The Upper Piltun Fault ruptured in the 1995 Neftegorsk earthquake and produced surface displacement over a length 35km. Maximum right-lateral slip in the earthquake was 8 m although average slip along the surface rupture was less than half that amount. The surface rupture exhibited left-stepping en-echelon surface displacements that segmented the zone of primary right-lateral shear (Streltsov et al., 1995).

Georisk (2005) indicates that the individual faults of northeastern Sakhalin Island are related, branching elements within a regional system of a right-lateral transpressional shear. This model suggests that surface ruptures in northern Sakhalin will result from strike-slip movements on faults with steeply dipping planes and narrow zones of related deformations.

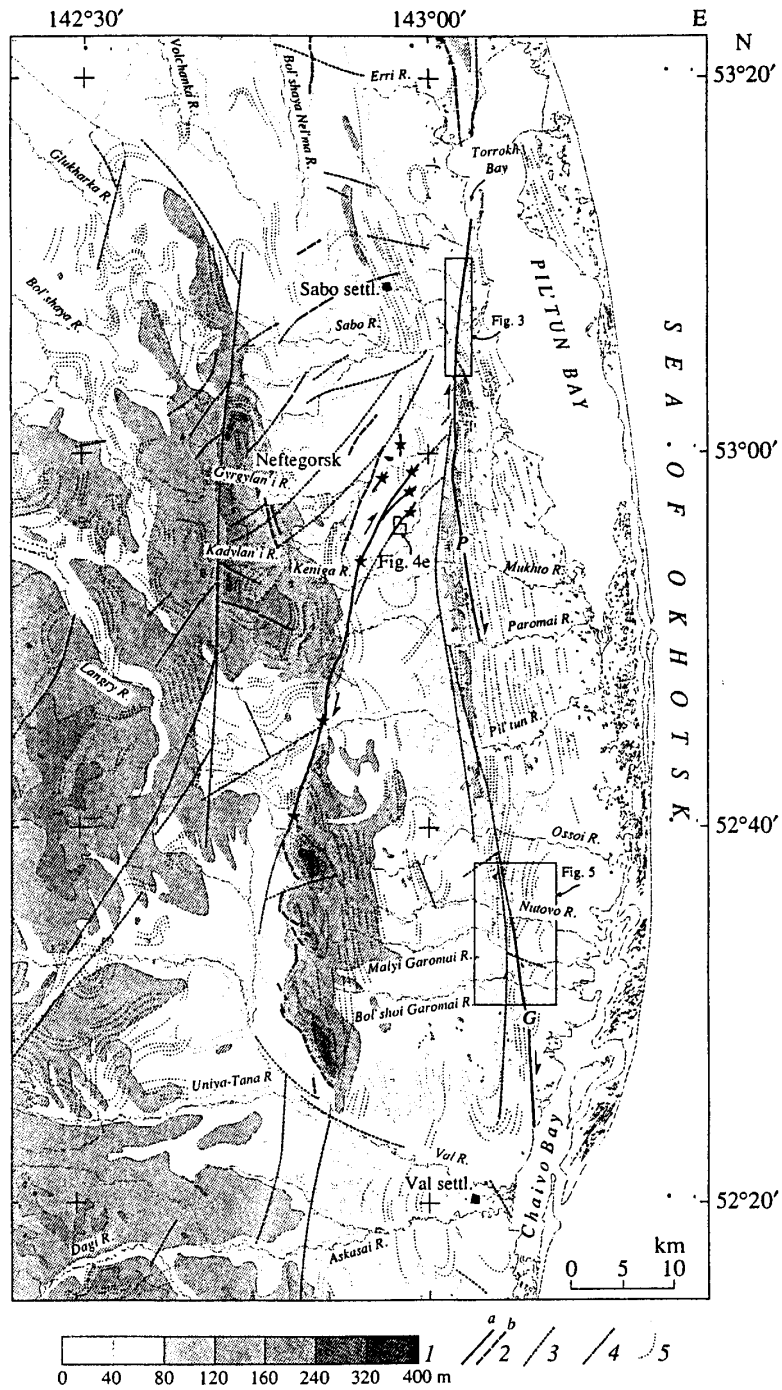

Figure 8.6. Faults and lineaments in Northeastern Sakhalin Island (from Bulgakov and others, 2002). (1) elevation scale, (2) active faults proved (a) and inferred (b), asterisks designate Neftegorsk earthquake faulting, (3) faults identified in ground survey and revealed as lineaments in space images, (4) largest lineaments discernable in space images, (5) Neogene beds; (P) and (G) denote the Piltun and Goromai active faults, respectively

8.4.2.2 Earthquake Magnitude

M_{LH} is an instrumental magnitude scale that is widely used in Russia and quoted in a number of Russian reports for the Sakhalin II project (Georisk, 2001). M_{LH} is a long-period teleseismic magnitude measure that is generally comparable to surface-wave magnitude (M_S), which is commonly used in western seismological studies. Table 8.1 compares values for various magnitude measures found in Sakhalin II earthquake reports (from Georisk, 2001).

Table 8.1: Relationship Between M_{LH} and M_w Magnitudes

Type	Magnitude Values										
M_w	4.50	5.00	5.50	6.00	6.50	7.00	7.50	8.00	8.50	9.00	9.50
M_S	3.59	4.34	5.10	5.79	6.53	6.91	7.38	7.75	8.02	8.26	8.47
M_{LH}	3.69	4.44	5.20	5.90	6.53	7.11	7.55	7.90	8.22	8.46	8.67

All instrumental measures of earthquake size, however, tend to saturate for earthquakes greater than about M_{LH} 8.0. Moment magnitude (M_w), on the other hand, is not an instrumental measure of earthquake size. This magnitude measure is physically related to the dimensions of the fault rupture that causes the earthquake. M_w does not saturate with earthquake size and is therefore a more meaningful measure when working with the physical fault manifestations of earthquakes. In the summaries of technical investigations that follow, earthquake size is referenced in terms of moment magnitude (M_w). However, references to the size of historical earthquakes are given in terms of their original M_{LH} magnitude assignments.

8.4.2.3 Earthquake Recurrence on Northern Sakhalin Faults

Paleoseismological studies have found evidence of strong prehistoric earthquakes on the Piltun-Goromai Fault. Average recurrence intervals for these events range between 2,300 and 5,000 years based on fault trenching investigations and ^{14}C age dating (Georisk, 2005; Besstrashnov et al., 1999; Bulgakov et al., 2002). In addition, a cluster of at least three events in the last 1,800 years has been identified within the rupture zone of the 1995 Neftegorsk earthquake on the Upper Piltun fault with another independent event dated at approximately 4,000 years before present (Besstrashnov and Strom, 1998). Georisk (2005) lists average recurrence frequencies of between 400 and 5,000 years based on these paleoseismological investigations. Bulgakov et al. (2002) previously concluded that earthquakes $6.75 \leq M_w \leq 7.75$ have recurrence frequencies of several hundred to several thousand years in northern Sakhalin Island.

8.4.2.4 Central and Southern Sakhalin Faults

The project facilities in relation to the active faults in Central and South Sakhalin are shown on Maps No. 2 and 3. Active structures of Central and Southern Sakhalin Island are concentrated along and near the eastern and western margins of the actively uplifting West Sakhalin Mountains. In central Sakhalin, the Kliuchevskoi fault defines the active thrust boundary between the Central Sakhalin Depression and the West Sakhalin Mountains (Figure 8.7). South of Terpenya Bay, the Kliuchevskoi fault defines the structural boundary between the West Sakhalin Mountains and the Susunai Depression (the analog to the Central Sakhalin Depression in central Sakhalin). The Kliuchevskoi fault is an active west-dipping thrust fault that juxtaposes Neogene deposits of the West Sakhalin Mountains block over Quaternary valley sediments.

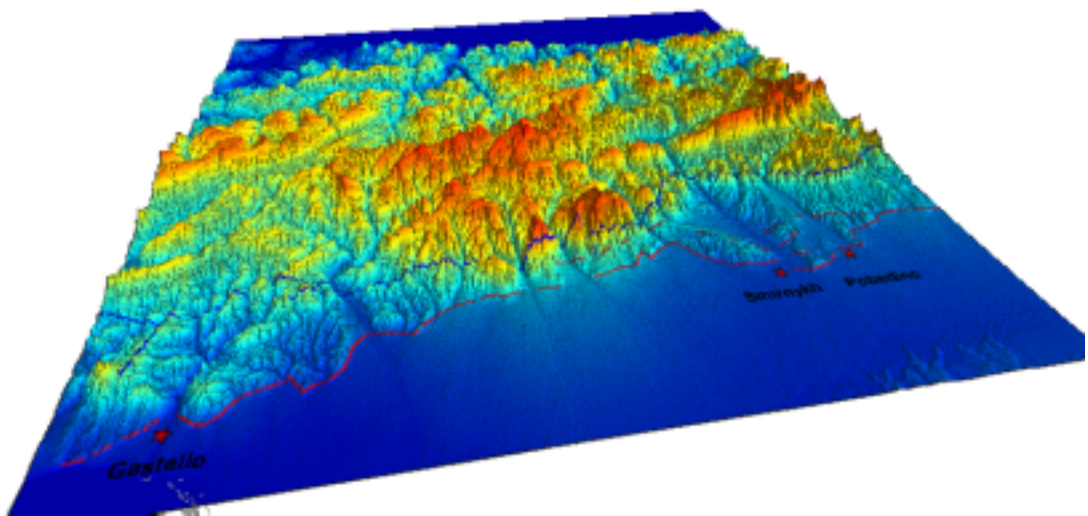

Figure 8.7. View looking to the west at hanging wall faults to the Kliuchevskoi fault near Pobideno. The Kliuchevskoi fault (red line) and Central Sakhalin fault (blue line) are taken from Bulgakov and others (2002). Digital elevation data from USGS.

The Central Sakhalin fault (Figure 8.8) is widely referenced in geological literature as the eastern structural boundary of the West Sakhalin Mountains (e.g., Bulgakov, 2002; Fournier et al., 1994) as this thrust fault emplaces Cretaceous rocks to the west over younger Neogene sediments to the east. However, the Central Sakhalin fault appears mostly inactive in the contemporary structural setting since the youngest surface faulting occurs along the Kliuchevskoi fault (Figure 8.8). Geophysical data indicates that the Kliuchevskoi fault merges with the Central Sakhalin fault at a depth of 4 to 5 km beneath the West Sakhalin Mountains.

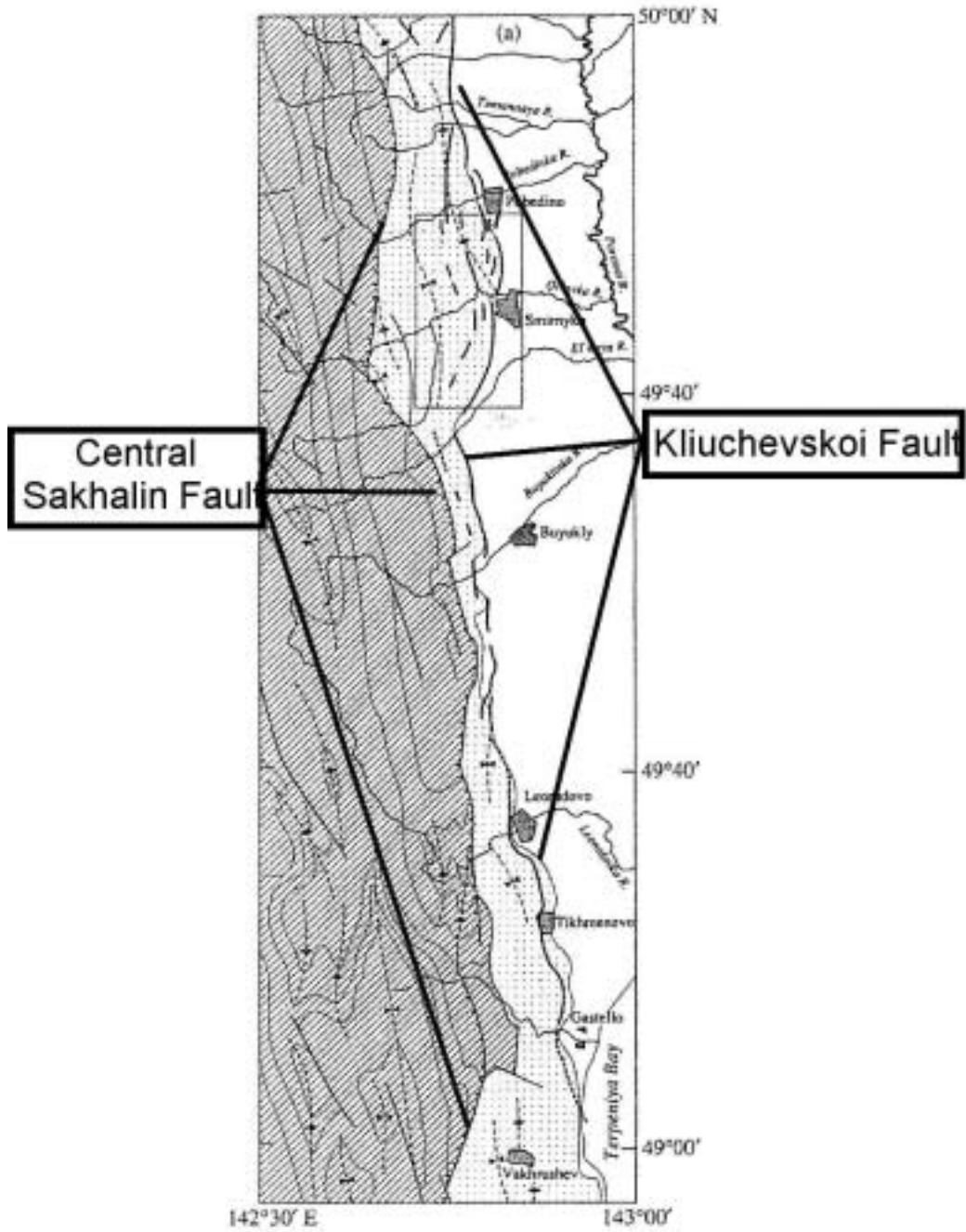

Figure 8.8. Map showing the relative locations of the Kliuchevskoi and Central Sakhalin faults (Bulgakov and others, 2002). Hatched pattern indicates Upper Cretaceous rocks. Dotted pattern indicates Neogene sediments. No pattern indicates Quaternary deposits.

In the region between Pobedino and Smirnikh settlements (see box area in Figure 8.8), short, en-echelon faults have formed in the hanging wall of the Kliuchevskoi fault due to internal deformation of the overthrust block (Bulgakov, 2000; Starstoi, 2004). These are secondary fault features (i.e., bending-moment or back-thrust reverse faults) related to co-seismic displacement on the primary Kliuchevskoi thrust fault.

8.4.2.5 Segmentation of the Kliuchevskoi Fault

Regional fault systems in general do not rupture over their entire length in a single earthquake. Typically, an earthquake ruptures only a limited length of an entire fault zone. Repeated ruptures over confined segments of the fault over long periods of time can lead to distinctive structural or geometrical traits among different lengths of the fault zone that is referred to as fault zone segmentation. Fault segments are inferred to have some control over the rupture lengths of earthquakes, although it has been observed in well-studied fault zones that segments boundaries are not temporally persistent, and can change over time. Georisk (2005) tentatively identified 11 distinct geometrical segments to the Kliuchevskoi fault through central and southern Sakhalin Island and the Piltun and Goromai segments in northeastern Sakhalin (Figure 8.9). The Upper Piltun fault that ruptured in the 1995 Neftegorsk earthquake exists as a single fault segment. Other than the Upper Piltun fault segment, there is insufficient paleoseismological data on the Island to know with certainty that each of these segments defined on geometric changes in the fault zones have actually controlled the lengths of previous earthquake ruptures. Nonetheless, the segmentation model provides a working hypothesis from which empirical correlation equations of rupture length vs. net displacement, based on worldwide fault rupture data (e.g., Wells and Coppersmith, 1994), may be used to estimate future displacements.

The Georisk (2005) Table 2 provides estimated net displacements for the main-fault pipeline crossings based on the segmentation model in Figure 8.9. Accounting for uncertainties in both the segmentation model and the statistical correlation equations, Georisk show that the majority of main-fault design displacements assessed in their Table 1 are at or above the 85th-percentile of maximum estimated displacement values for each of the defined segments. Only three crossings are lower, and even then, these are at or above the 65th-percentile estimated value. These statistical treatments of the fault data provide confidence that the net displacements in Table 8.2 of this Addendum, which are based on observational data and compiled by ABSC (2005), provide a reasonable level of conservatism as recommended design values.

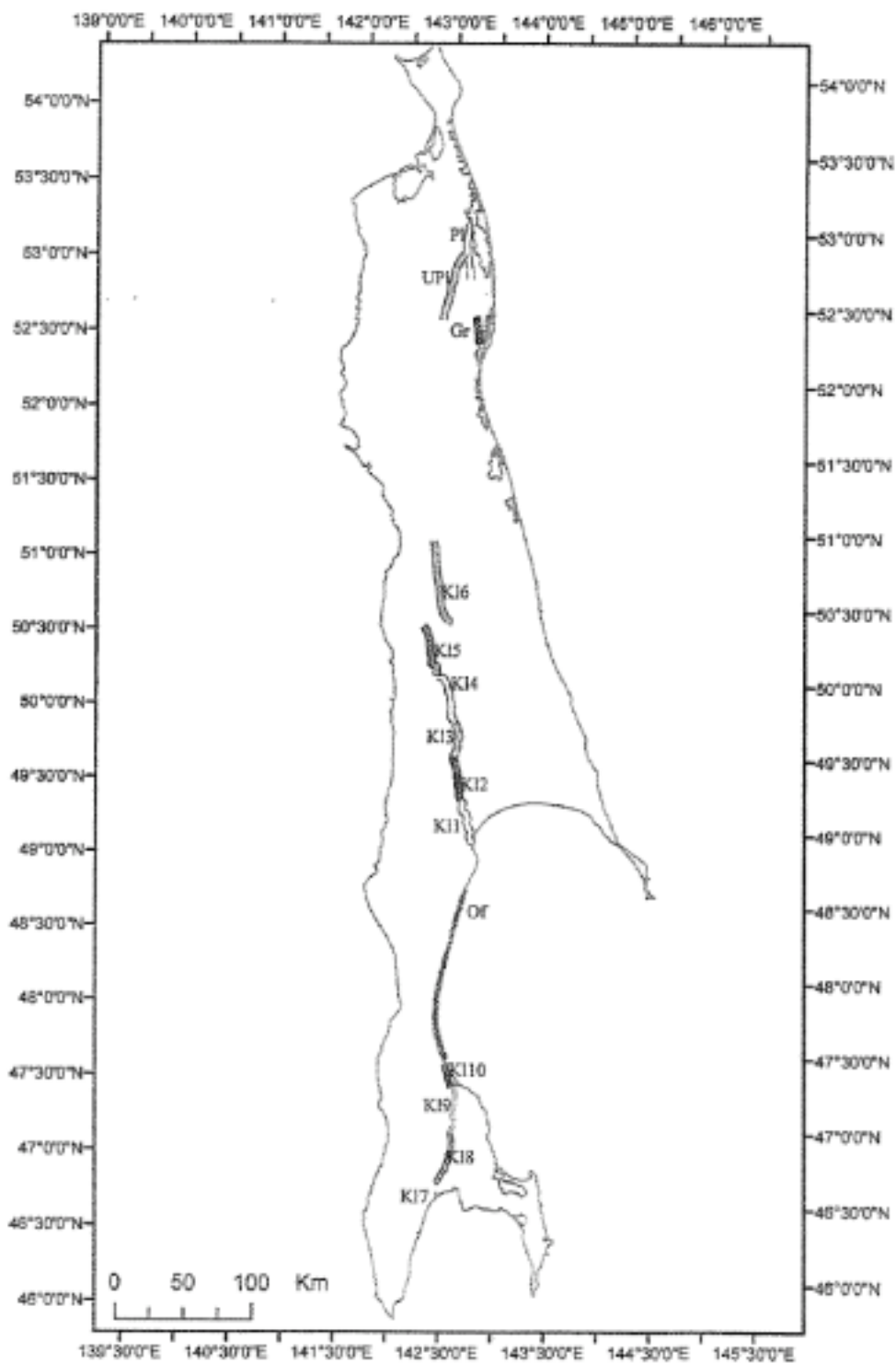

Figure 8.9. Map showing the fault segmentation model for active faults near or along the Sakhalin II pipeline routes.

8.5 GEOLOGIC HAZARDS

8.5.1 Surface Fault Rupture

Rupture of an active fault to the surface during an earthquake poses a ground displacement hazard to structures located across the fault. Such displacements typically accompany earthquakes having magnitudes of about M_w 6.5 and greater. The rupture areas of smaller earthquakes that occur at seismogenic depths are generally too small to penetrate to the surface. The previously described 2000 Ulegorsk (M_{LH} 6.8) and 1995 Neftegorsk (M_{LH} 7.2) earthquakes caused offset along their surface traces. Field investigations have defined other surface offsets that occurred during the last 10,000 years (Holocene Epoch) and earlier along the Piltun-Garomai, Upper Piltun, and Kliuchevskoi, faults. The Sakhalin II export pipelines cross the Piltun-Garomai, and Kliuchevskoi faults. The Kliuchevskoi fault has a very sinuous trace that generally follows along the base of the West Sakhalin Mountains front. The pipeline route therefore crosses this fault a number of times as it follows the western margin of the Central Sakhalin Depression southward to the processing facility at Prigorodnoye. The pipeline route and the fault crossing locations are shown on Maps 1 to 3.

Expected horizontal and vertical displacement at each of the pipeline-active fault intersections is given in Table 8.2. These estimates were developed from field investigations at each of the crossing intersections by Russian (Starstroi/Georisk) and western consultant (ABS Consulting) field teams. Along the Kliuchevskoi thrust fault, the displacement values of primary significance are the vertical components at each of the pipeline intersections with the fault. The vertical component is dominant in this case because of the fault's overall north-south trend relative to a horizontal maximum compressive stress orientation of approximately N 70° E (Fournier et al., 1994). Components of lateral displacements to which the pipeline is subject are subordinate in magnitude to the vertical component and will vary with respect to the fault-crossing angle. Detailed descriptions of the individual crossings for each pipeline-active fault intersection may be found in ABS Consulting (2005) and Georisk (2005). Recommended displacement values for the pipeline crossings are provided in Table 8.2. A brief description of the geological investigations and findings at each of the crossings is given in the following section.

Table 8.2: Recommended Displacement Parameters for Fault Crossings of the Sakhalin II Pipeline

No.	Dwg. Sheet	Name	KP Existing	Fault Tolerance ± m	Mode of Faulting	V (Vert.) (m)	S (Strike) (m)	T (Trans.) (m)	Horiz. Displ. in Direction N70°E	Net (m)	Vertical Displacement Determination Method
(1)	(2)	(3)	(4)	(5)	(6)	(7)	(8)	(9)	(10)	(11)	(12)
1	12	Goromai (original route)	NOTE: Pipeline has been rerouted to cross the Goromai fault at the "1-Alt" location. This crossing has been eliminated.								
1 Alt	N/A	Goromai (Piltun reroute)	15.23 on the current Piltun re-route alignment.	25	Oblique right-lateral	1.0	5.4	0.13	N/A for a strike-slip fault.	5.5	Trenching 2005 and considering Neftegorsk displacements. "T" is a function of V and based on a 70° fault dip.
2	N/A	Hokkaido-Sakhalin	NOTE: No active crossing of the pipeline by the Hokkaido-Sakhalin fault was identified during the ABSC June-July 2005 fieldwork. This crossing has been eliminated.								
3	173 to 177	Kliuchevskoi (Yasnoye section)	118-119	50	Thrust	2.3	N/A	N/A	2.3	3.3	Surface Profile 2005. V based on T1 terrace riser measured in 2005.
4	208	Kliuchevskoi (Desiataya rechka)	180	N/A	Thrust	2.1	N/A	N/A	2.1	3.0	Surface Profile and Trench 2005.
5	211 and 212	Kliuchevskoi (South Khandasa section)	185.875	50	Thrust	2.5	N/A	N/A	2.5	3.5	Trenching 2004.
6	213	Kliuchevskoi (Branch of main fault)	188.700	10	Thrust	0.7	N/A	N/A	0.7	1.0	Trenching 2004.
7	224	Kliuchevskoi (Pobedino section)	208.545	20	Thrust	2.0	N/A	N/A	2.0	2.8	Surface Profile 2004.

No.	Dwg. Sheet	Name	KP Existing	Fault Tolerance ± m	Mode of Faulting	V (Vert.) (m)	S (Strike) (m)	T (Trans.) (m)	Horiz. Displ. in Direction N70°E	Net (m)	Vertical Displacement Determination Method
(1)	(2)	(3)	(4)	(5)	(6)	(7)	(8)	(9)	(10)	(11)	(12)
8	232	Kliuchevskoi (Smirnikh section)	223.740	20	Thrust	2.0	N/A	N/A	2.0	2.8	Published trenching study in 2000 and project trench in 2004.
9	275	Kliuchevskoi (Gastello section)	300.590	50	Thrust	2.0	N/A	N/A	2.0	2.8	Field assessment 2004.
10	275	Gastello Hanging wall (Kliuchevskoi Hanging Wall Fault)	301.605	10	Oblique Left – Lateral	1.0	0.5	0.0	N/A	1.1	Trenching 2004.
11	297	East Makarov Additional-3 (Fault trace needs to be added to Map 297) (Kliuchevskoi Hanging Wall Fault)	342.540	20	Oblique Right – Lateral	0.5	0.5	0.0	N/A	0.7	Trenching 2005.
12	297	East Makarov Additional-2 (Kliuchevskoi Hanging Wall Fault)	342.655	10	Oblique Right – Lateral	0.5	0.5	0.0	N/A	0.7	As for No 11 trenching.
13	297	East Makarov Additional-1 (Kliuchevskoi Hanging Wall Fault)	342.720	10	Oblique Right – Lateral	0.5	0.5	0.0	N/A	0.7	As for No 11 trenching..
14	297 and 298	East Makarov (Kliuchevskoi Hanging Wall Fault)	342.955	10	Oblique Right – Lateral	1.0	1.0	0.0	N/A	1.4	Trenching 2003.

No.	Dwg. Sheet	Name	KP Existing	Fault Tolerance ± m	Mode of Faulting	V (Vert.) (m)	S (Strike) (m)	T (Trans.) (m)	Horiz. Displ. in Direction N70°E	Net (m)	Vertical Displacement Determination Method	
(1)	(2)	(3)	(4)	(5)	(6)	(7)	(8)	(9)	(10)	(11)	(12)	
15	300	West Makarov (Kliuchevskoi Hanging Wall Fault)	347.265	10	Oblique Right – Lateral	1.5	1.5	0.0	N/A	2.1	Trenching 2003.	
16	372	Chernaya River (Kliuchevskoi Hanging Wall Fault)	481.450	20	Oblique Left – Lateral	0.5	0.5	0.0	N/A	0.7	Starstroi field assessment 2004.	
17	378	Kirpichnaya River (Kliuchevskoi Hanging Wall Fault)	492.688	20	Oblique Right – Lateral	1.0	1.0	0.0	N/A	1.4	Starstroi field assessment 2004.	
18 Alt	387	Kliuchevskoi (South from Sovetskoe)	509.176	20	Thrust	2.7	N/A	N/A	2.7	3.8	Surface Profile 2004.	
19	394	Kliuchevskoi (Lebiazhia River Section)	NO ACTIVE FAULT AT THIS LOCATION								2005 geophysical and topographic investigations.	
20	419	Kliuchevskoi (West from Yushnyi)	567.000 – 567.200	50	Thrust	3.0	N/A	N/A	3.0	4.2	Trench and Surface Profile 2004.	
21	420 and 421	Kliuchevskoi (West from Yushnyi)	569.430	50	Thrust	3.0	N/A	N/A	3.0	4.2	Trench and Surface Profile 2004.	

Notes:

For reverse/thrust faults, the horizontal displacement component (Column 10) is given for the maximum compressive stress direction of N70°E. This applies to the Kliuchevskoi fault crossings (Fault crossing numbers 3, 4, 5, 6, 7, 8, 9, 18, 18 Alt, 19, 20, and 21).

1. Faults 10 to 17 are hanging wall faults (secondary) to the main Kliuchevskoi thrust fault. These faults are high angle and the given values of vertical and horizontal displacements should be used in design.
2. The values listed in column 5 (Fault Tolerance) are confidence values in the fault location (perpendicular to the fault strike) specific to the pipeline/fault crossing location. If the pipeline/fault crossing locations change, new location confidence values should be determined.

8.5.1.1 Piltun-Goromai Fault (Table 8.2, No. 1 and 1 Alt.)

The final crossing location is “1-Alt” in Table 8.2. The Piltun-Goromai fault trends generally north-south for a distance of 90 km between Chayvo and Piltun bays and continues northward into the Schmidt Peninsula at the northern tip of Sakhalin Island. The fault zone has long been recognized in the Russian geological literature as a fundamental right-lateral strike-slip fault zone of the northeastern Island region. Secondary compressive and extensive geological structures are found along the fault, which can be correlated to minor changes in fault strike relative to the uniform northeast-southwest trending principal compressive tectonic stress direction. At the pipeline crossing location 1-Alt, the scarp is distinctively linear. Examination of a trench excavated across the fault scarp during the 2005 field season revealed structures in the shallow soils consistent with compressive thrust displacements. However, these structures are truncated by a younger narrow shear zone, which is subvertical but non linear in the trench wall, and sub-linear in the trench floor. This fault trace has associated sand injection structures, and juxtaposition of lithologies that would not appear to be consistent with vertical displacement. The fault is additionally postdated by “Riddel”-like structures comprising narrow vertical silt injections oriented at approximately +30° (clockwise) to the fault trace in the trench floor. The fault trace and subsequent injection structures are consistent with right-lateral strike-slip movement.

8.5.1.2 Hokkaido-Sakhalin Fault (Table 8.2, No. 2)

In the vicinity of the Lunskeye Onshore Processing Facility (OPF), Starstroi (2004) indicated a suspected active surface rupture along the Hokkaido-Sakhalin fault zone near the eastern coast of Sakhalin Island. This feature was identified from space photography and was shown to extend to within perhaps 10 km southwest of the OPF.. The area around the projected intersection of the possible fault with the pipeline was examined in the 2005 field reconnaissance. No evidence of a fault (either young or old) was found. Either the lineament identified by Starstroi south of the pipeline is not a fault at all, or the fault terminates well to the south of the pipeline route, or the fault is inactive.

8.5.1.3 Kliuchevskoi Fault, Yasnoye Section (Table 8.2, No. 3)

This fault scarp was identified on aerial photography and in the field as a scarp exhibiting Holocene surface displacement. At location 620397 E and 5607298 N, a stream cuts transversely through the fault scarp. The total fault scarp is 5 to 6 meters in height. Stream terraces in the hanging-wall of the scarp are elevated 2 to 3 meters above the current stream grade indicating repeated fault movement to produce the 5 to 6 meter high scarp. The last event raised the stream terraces 2.3 metres above the current stream grade. The 2.3 meter vertical displacement value is recommended for design of the pipeline fault crossing.

8.5.1.4 Kliuchevskoi Fault, South Onor (Removed from Table 8.2)

Trenching investigations of this scarp feature revealed no evidence of shear planes through the shallow soil column. Distinct sub-horizontal marker beds in the walls of the trench dipped gently to the north and gradually increase in dip to the southern end of the trench and onto the scarp feature. All the clasts (gravel) in

the deposits were rounded to sub-rounded with the flat sides of the clasts oriented parallel to bedding. This indicated that the marker beds were fluvial deposits and that the gentle increase of bedding dip into the scarp was fluvial in origin and not caused by fault displacement. Following joint field reconnaissance of this feature, including review of the open trench, it was concluded that there was no fault at this location and the site was removed from the list of active fault crossings.

8.5.1.5 Kliuchevskoi Fault, Desiatayarechka, (Table 8.2, No. 4)

A joint field reconnaissance of this feature was conducted in 2005. A trench was excavated on the west side of the pipeline right-of-way. Evidence of a fault and two thrust-faulting events was found. Two stream terraces were measured above the existing floodplain. The vertical displacements in the last two surface-rupturing earthquakes are reflected in the height of the terraces above the present floodplain. The measured heights were 1.9 m and 2.1 m for the youngest and the penultimate displacement, respectively. The larger displacement, 2.1 m was recommended as the design vertical displacement value.

8.5.1.6 Kliuchevskoi Fault, South Khandasa (Table 8.2, No. 5)

A fault scarp was observed at Kp186 and is about 5 meters high. Trenching investigations exposed a sequence of sub-horizontal blue and brown clays in the footwall of the fault deposited unconformably against an intervening 10-meter wide deposit of river gravels that dip 5° to the south. The river gravels are deposited unconformably on an older sequence of clays. No shear plane was observed in the exposure of the trench. Although no fault was found in the trench, the geologic relationships of clays and river gravels were inferred to represent two surface folding events. A reconstructed folding sequence yielded a 5-meter high fold scarp with two folding events resulting in an average 2.5 meters of vertical uplift per folding event, which is the recommended design vertical displacement at this crossing.

8.5.1.7 Kliuchevskoi Fault, Branch of Main Fault (Table 8.2, No. 6)

The Kliuchevskoi fault crosses the pipeline near Kp 189 (Starstroi, 2004b). This location was excavated during the joint field reconnaissance in Autumn 2004. A fault was found in the trench exposure at the base of the scarp. The fault had thrust displacement, a north-south strike, a dip of 50° to the west, and a vertical displacement of 0.7 meters, which is the recommended design vertical displacement.

8.5.1.8 Kliuchevskoi Fault, Pobideno Section (Table 8.2, No. 7)

The Kliuchevskoi fault crosses the pipeline at Kp 208.5. The fault trends generally east-west and exhibits a 2 metre high scarp. The trend of fault scarp changes from east-west to north-south about 100 meters east of this pipeline crossing and the height of the fault scarp increases from 2 meters at the east-west trending location to about 5 meters where the scarp trends north-south. By analogy with the Kliuchevskoi fault scarp in the Smirnykh Section, the 5 metre scarp represents more than one event as discussed by ABSC in Section 2.3.3 in Part 2 of their 2005 report as it relates to the Smirnykh trench log of Bulgakov et al. Multiple events are also recorded in the trench at crossing No 8 (see below). The fault kinematics are consistent with fault motion driven by a maximum horizontal

tectonic compressive stress oriented approximately N 70° E (Fournier et al., 1994). The recommended design vertical displacement is 2.0 m, twice the single event displacement value for the east-west scarp with its dominant strike-slip component. This value conservatively reflects the observed total vertical displacement at the crossing.

8.5.1.9 Kliuchevskoi Fault, Smirnikh Section (Table 8.2, No. 8)

Trenching investigations west of Smirnikh village exposed a 6-meter wide shear zone at the base of this fault scarp with three distinct shear planes trending north-south that dipped on average 45° west. Total stratigraphic offset within the 6-meter wide zone between the shear planes was 2.0 m, although there was evidence that the three shear planes did not all move in the same surface-faulting event. Nonetheless, lacking a finer resolution to the individual events, the total 2m offset was recommended as the design vertical displacement.

8.5.1.10 Kliuchevskoi Fault, Gastello Section (Table 8.2, No. 9)

A hand-excavated trench across this fault scarp where it crosses Kissa Creek near pipeline Kp 300.6 did not expose a fault. However, uplifted stream terraces exist in the hanging wall block along the margins of Kissa Creek, but are absent in the footwall block. The lack of terraces in the footwall and their presence in the hanging-wall is evidence of movement on the Kliuchevskoi fault at this location. The youngest uplifted terrace was 1.5 to 2.0 meters above the present grade of Kissa Creek flood plane indicating the amount of vertical offset by the last surface faulting event. The recommended design vertical displacement at this location is 2.0 m.

8.5.1.11 Gastello Hanging-wall Fault (Table 8.2, No. 10)

One-half kilometre west of the surface trace of the Kliuchevskoi fault at Kissa Creek is a down-to-the-west fault in the hanging-wall block of the Kliuchevskoi fault. The fault scarp at this location was 5 meters high. Trenching at this location exposed the main fault plane and a sequence of buried soils in the footwall. Four buried soils with associated colluvial wedges indicated that this fault had five episodes of movement. Parameters of the main fault plane are N 7° W, dipping 82° east, with fault striae that dip 62° to the south. The south-dipping striae indicate that the fault has a component of left-lateral displacement. The 62° dip of the striae indicates the last movement on this fault had 2 parts vertical displacement to 1 part left-lateral displacement. The fault scarp is 5 meters high with evidence from the trenching investigation of 5 fault movements yielding 1 meter of average vertical displacement and 0.5 meters of left-lateral displacement per faulting event, which are the recommended design displacements.

8.5.1.12 East Makarov Faults (Table 8.2, No's. 11 to 14)

In a 0.5-km stretch of the pipeline route near the town of Makarov (Kp 342.54 to Kp 342.96), the pipeline crosses the traces of four well-defined surface-rupturing faults. All of these faults are in the hanging-wall of the Kliuchevskoi fault. The Kliuchevskoi fault proper is actually offshore to the east of this location. The surface traces of these hanging-wall faults are sub-parallel, NNW-trending, and nearly linear. All of the faults exhibit down-to-the-west displacement, the scarp at

fault 14 is more significant than the scarps of the other three to the north-east. The linear surface traces indicate that the faults are either steeply dipping or vertical, precluding a large component of thrust displacement. Fault 14 was investigated by trenching 1.8 km south of the pipeline crossing, and the results from the trench yield displacement values of 1.0m vertical and 1.0m strike-slip displacements. Trenching near the fault crossing of fault 11 yield values of 0.5m vertical and 0.5m strike-slip displacements. These values were applied to faults 12 and 13 which have similar surface expression.

8.5.1.13 West Makarov Fault (Table 8.2, No. 15)

Fault striae observed on the main fault plane in trenching investigations indicates that this fault is steeply dipping and has a component of right-lateral displacement. The information derived from the main fault plane yielded right-lateral fault movement on a fault plane striking N16° E and dipping 88° W. Striae on the fault plane dipped 15° from horizontal to the north. General shear fabric of the fault zone supported the observation of a right-lateral shear component, although the height of the scarp indicated a fairly substantial component of vertical displacement. A 1:1 vertical-to-horizontal displacement ratio was recommended from the observations of fault striae and scarp morphology with a vertical displacement of 1.5 m.

8.5.1.14 Chernaya River Fault Crossing (Table 8.2, No. 16)

The Chernaya River fault crossing exhibits a NNW-trending linear surface rupture in the hanging-wall of the main Kliuchevskoi fault, which is located offshore to the east from the Chernaya River location. The structural position, scarp height and length is similar to the East Makarov faults (Section 1.3.1.12 above) except that the sense of lateral displacement is opposite to that of the Makarov faults. Recommended design displacements are accordingly similar, except for having the opposite sense of lateral displacement.

8.5.1.15 Kirpichnaya River Fault Crossing (Table 8.2, No. 17)

The Kirpichnaya River fault is a NNE trending linear surface rupture mapped in the hanging-wall of the Kliuchevskoi fault by Starstroi (2004). The fault exhibits characteristics similar to other hanging-wall faults of the Kliuchevskoi fault previously described and has a right-lateral component of movement. Design displacements were recommended in accord with fault number 14 of the East Makarov group of faults based on the similarity of the two faults' structural characteristics and scarp morphology.

8.5.1.16 Kliuchevskoi Fault, Kirpichnaya Mouth Section (No. 18, Removed from Table 8.2)

The area around the mouth of the Kirpichnaya River was surveyed to assess the location of the fault at the pipeline crossing between Kp 496 and Kp 497. Field reconnaissance south of the river located a distinct east-facing scarp at the southwest margin of a large gravel pit that was located 400 meters west of the pipeline route and one kilometre south of the river. Offset bedding exposed in the gravel pit at this location confirmed a fault origin for the scarp. The offset bedding is down to the northeast. The trend of the fault adjacent to the gravel pit is generally north-south.

Reconnaissance north of the river mouth identified a northeast-trending, down-to-the-southeast scarp crossing the margin of a high terrace and a raised Holocene marine terrace adjacent to the coast between the railroad and the highway. This scarp intersected a Holocene beach ridge where a vertical separation of the beach ridge crest was measured as 2.7 m down-to-the-southeast, which was provided as the design vertical displacement. This crossing was later bypassed.

8.5.1.17 Kliuchevskoi Fault, South of Sovetskoye (Table 8.2, No. 18 Alt)

Southwest of Sovetskoye village, the Kliuchevskoi fault offsets a flight of fluvial terraces along the Ay River. The fault is marked by a sharp, well-preserved scarp trending generally north-south. The fault exhibits a growth history expressed by increasing scarp height in higher (older) terraces. The active floodplain terrace, a few meters above the river channel, is not faulted. However, a prominent scarp crosses the lowest (youngest) raised terrace and it is offset vertically 2.7 m across the scarp. This vertical offset is judged to be a minimum value because the base of the scarp on the down-faulted footwall may have been buried by over-bank sediments deposited by a small stream that flows along the fault. The lack of soil development on this terrace indicated it is late Holocene. The 2.7 m vertical offset of the terrace appears to be the result of a single faulting event.

The fault cuts the second raised terrace in the terrace sequence on the south side of the Ay River. A surveyed profile of the scarp shows it has a complex form that is characteristic of a low angle thrust with fault bends and a prominent scarp 6.44 m high. The 6.44 m high scarp is interpreted to reflect faulting from two displacement events. However, because of the complex scarp geometry at this location associated with a fault-bend fold-scarp, the vertical separation of the terrace across the fault is less than the scarp height by the vertical separation across the backscarp (0.99 m). Therefore, the total tectonic vertical component of displacement for the two events is 5.45 m. Since the last event generated about 2.7 m of vertical displacement, the penultimate event on this part of the fault generated also produced about 2.7 m of vertical offset across the frontal scarp, which is the recommended design vertical displacement.

8.5.1.18 Kliuchevskoi Fault, Lebiazhia River Section (Table 8.2, No. 19)

Southeast of Sovetskoye the Kliuchevskoi fault has an approximately 3-km left step in the vicinity of the Lebiazhia River. Reconnaissance mapping found the fault continues for about one km to the north where it is marked by a gentle sloping 3m-high east facing scarp that displaces a low river terrace on the south side of the Haubo River valley. The gently sloping morphology of the scarp suggests the fault does not reach the ground surface where it displaces the terrace, but instead, forms a monoclinial fault-propagation fold, the Pokrovka fold.

To the north of the deformed terrace at Pokrovka, the trend of the fault projects for about 4 km across active floodplains and young meander belts of the Hauba and Lebiazhia Rivers. Reconnaissance of this area failed to find any geomorphic evidence of the fault in the low-lying flood plains. A series of seven trial pits were excavated to an average depth of 3.5 m during the 2005 field campaign to determine if soil lithologies abruptly changed along the pipeline right-of-way across the projected location of the inferred fault. Soil horizons were strongly exhibited in the test pits but there was no discernable difference in the depths of

the horizons among the seven pits, indicating that no offsets occur along the pipeline right-of-way. In addition shallow geophysical investigations provide evidence for no faulting at this location.

Based on this evidence, it is concluded that it is most likely that the trace of the Kliuchevskoi fault does not extend to the surface in the vicinity KP 520 (i.e., in the vicinity of crossing #19). It is believed that the geological expression of the blind Kliuchevskoi fault is the deformed Paleogene-Miocene sediments imaged on the seismic refraction lines but that faulting does not extend to the surface.

Undeformed Holocene peat sequences above the deformed Paleogene-Miocene sediments indicate that there has been no folding or faulting at this location in Holocene time, and perhaps not since at least the late-Pleistocene. These observations render any faulting or folding in this area inactive according to the project definition of active faults.

8.5.1.19 Kliuchevskoi Fault, West from Yuzhno (Table 8.2, No. 20 and 21)

Three geologic and geomorphic indicators of past fault displacement were examined and measured to characterize the recent paleoseismic history of the Kliuchevskoi fault west from Yuzhno. These are 1) the fluvial terraces upstream of the surface trace of the fault along Imanovka Creek, 2) shallow subsurface structures and stratigraphy exposed in a reconnaissance trench across the fault, and 3) the fault scarp where the fault cuts the stream terraces. Estimates of the vertical component of displacement for the last three faulting events were made from several data sets obtained from the trench, terrace, and scarp measurements. The vertical component of displacement during the most recent (Holocene) faulting event was determined to have been 4.0 ± 0.3 meters. The penultimate event generated 2.0 ± 0.3 meters of vertical displacement, and the antepenultimate event 2.0 ± 0.6 meters of vertical displacement. Characteristics of thrust faulting were commonly observed in these investigations and no evidence of strike-slip displacement was found. The recommended design vertical displacement of 3.0 m is calculated as the simple mean of the observed maximum and minimum displacements. No additional weight was given to the two 2.0-m displacement observations.

8.5.2 Earthquake Ground Motions

Among the Sakhalin II facilities ground motion hazard from earthquakes is highest at the platform sites offshore of the northeastern coast of the Island and at the OPF. This is due to the proximity of these facilities to the active Piltun-Goromai and Upper Piltun faults that dominate the ground motion hazard in this region (Figure 8.9). The LNG/OET/TLU facilities located near Prigorodnoye on the northeastern coast of Aniva Bay have lower ground motion hazard due to their distance from the primary seismic zones of the West Sakhalin Mountains and offshore of the western coast of the Island (Figure 8.10; EQE, 1996b; ABSC, 2002; RSIS, 1998; URS, 2002).

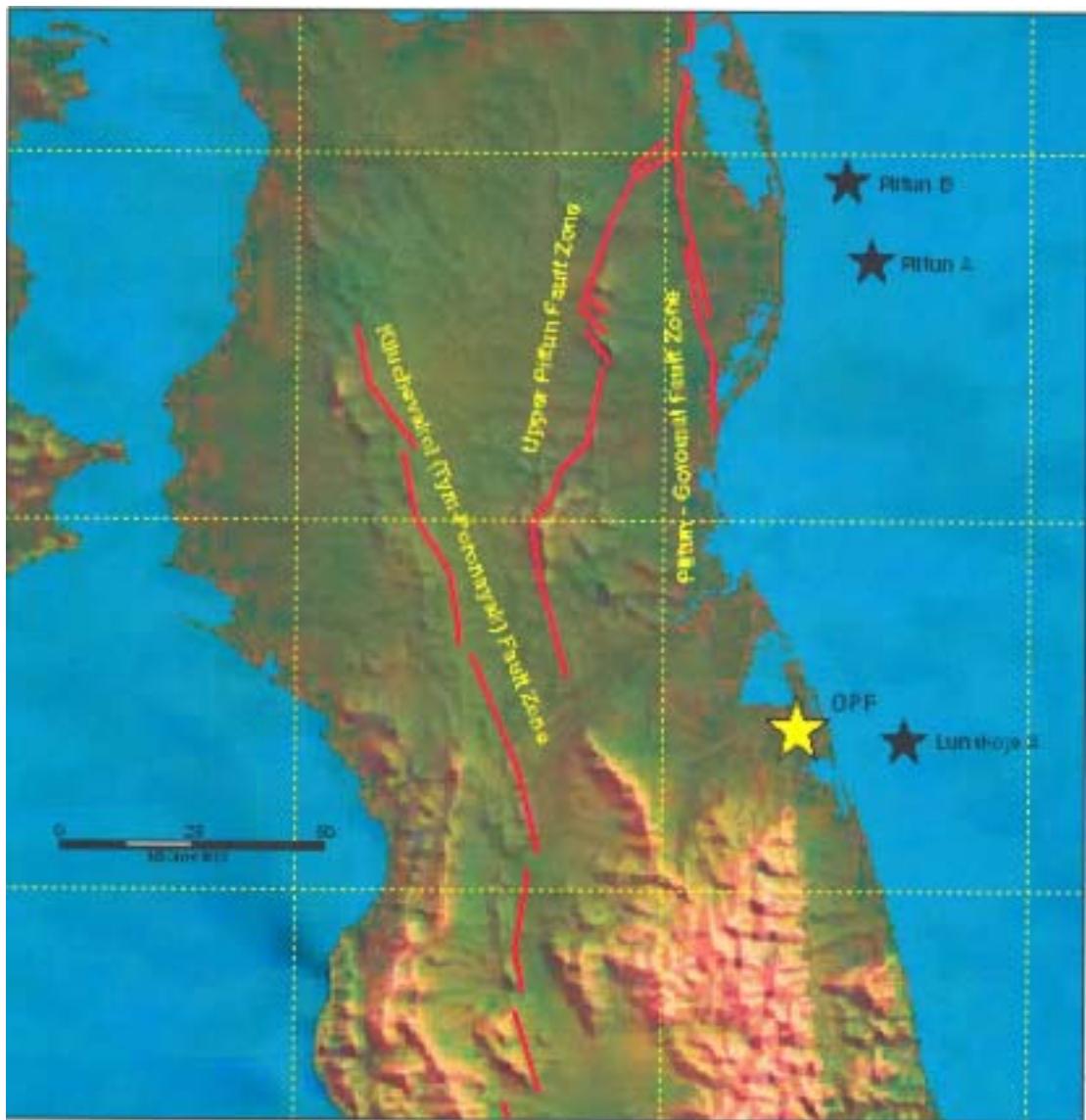

Figure 8.9. Location map of the Lunskiye-A, Piltun A and B platform sites, and Oil Production Facility (OPF) shown in relation to the active fault zones of northern Sakhalin Island. [

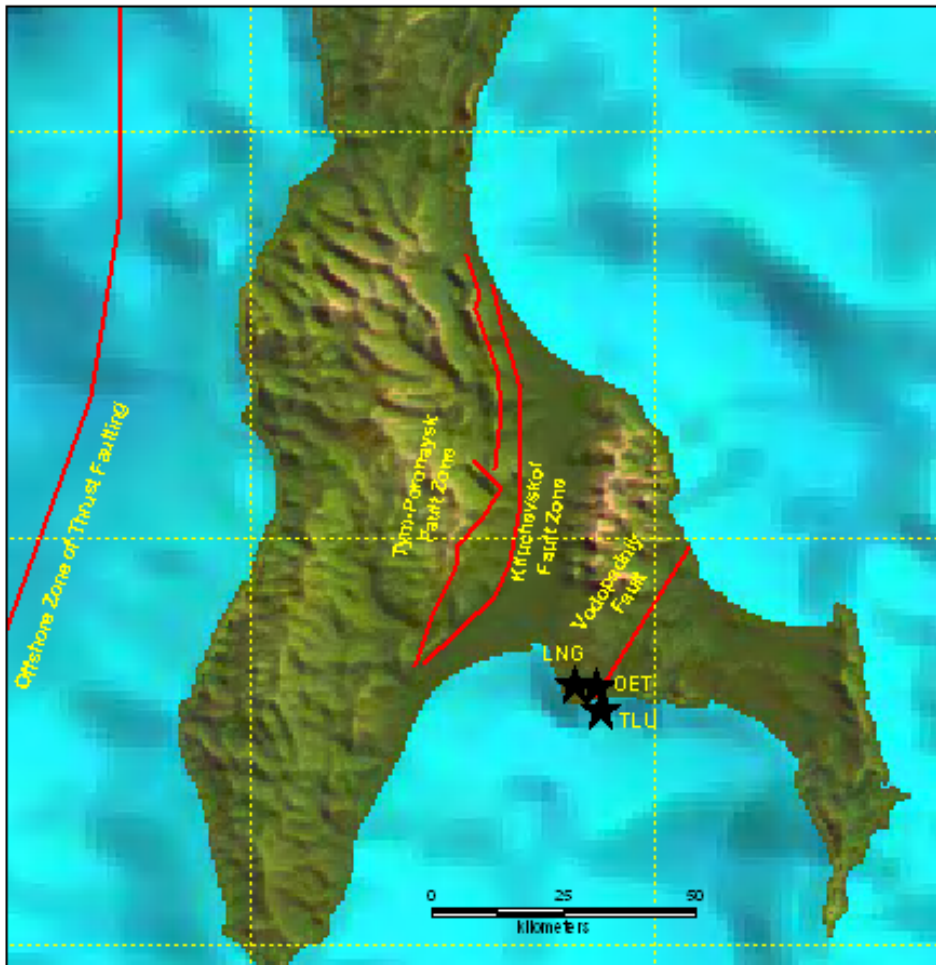

Figure 8.10. Location map of the LNG plant, Oil Export Terminal (OET), and Terminal Loading Unit (TLU) shown in relation to the active fault zones of southern Sakhalin Island.

8.5.3 Earthquake Recurrence

Transverse tectonic compression across central and southern Sakhalin Island caused by the ENE-trending compressive tectonic stress field (Fournier et al., 1994) is estimated to be on the order of 1 – 2 mm/year (Bulgakov et al., 2002). If we conservatively assume that all of this contraction is accommodated normal to fault strike along the length of the Kliuchevskoi fault, then an estimate of the recurrence frequency of the vertical displacements (Vert.) in Table 8.2 is simply a sine function of the dip angle of the fault. For an average convergence rate of 1.5 mm/year, annual vertical uplift rate on a 60°-dipping thrust fault is 1.30 mm/year, and 1.06 mm/year on a 45°-dipping thrust fault (see ABSC [EQE], 2000). The modal vertical displacement in Table 8.2 for the pipeline crossings of the Kliuchevskoi fault is 2 m (i.e., 2,000 mm). Dividing this modal displacement by the average annual uplift rates indicates a conservative estimate of the recurrence frequency of the modal vertical displacement in Table 8.2 of about 1,500 to 1,900 years, depending on the actual fault dip. Larger vertical displacements have proportionately longer recurrence frequencies. Because hanging-wall faults in thrust fault zones have a complex relationship to slip on the main thrust and bending moments in the hanging wall, this simple methodology is not likely to be appropriate for these faults.

8.5.4 Ground Motion Hazard Methodology

Probabilistic seismic hazard analysis (PSHA) developed for use in engineering design were performed for the Sakhalin II project (EQE, 1996b; URS, 2002; URS, 2002). PSHA consists principally of the following procedural elements for any given site:

- Development of seismic sources within the region of the site that define the possible locations for earthquake occurrences;
- Development of earthquake source data files for the region of concern that includes historical and instrumental seismicity data as well as paleoseismological data if it exists;
- Determination of earthquake frequency parameters (activity rate, Gutenberg-Richter b-value, and maximum credible earthquake) that govern the seismic characteristics of each source, based on the historical and instrumental earthquake occurrences as well as available geological data for larger earthquakes;
- Determination of an appropriate ground motion model representing the attenuation in ground shaking and its variability as a function of distance, magnitude, and vibration period;
- Evaluation of annual frequencies of exceeding chosen ground motion levels, according to the following formulation;

$$\lambda[X \geq x] \approx \sum_{Sources\ i} v_i \int_{M_o}^{M_c} \int_{R|M} P[X \geq x | M, R] f_M(m) f_{R|M}(r|m) dr dm$$

- where $\lambda[X \geq x]$ is the annual frequency that the site ground motion exceeds the chosen level $X=x$; ν_i is the annual rate of occurrence of earthquakes on seismic source i , having magnitudes between M_o and M_{Max} ; M_o is the minimum magnitude of engineering significance; M_{Max} is the maximum magnitude assumed to occur on the source; $P[X \geq x|M,R]$ denotes the conditional probability that the chosen ground motion level is exceeded for a given magnitude and distance; $f_M(m)$ is the probability density function of earthquake magnitude; and $f_{R|M}(r|m)$ is the probability density function of distance from the earthquake source to the site of interest;
- Compilation of the resulting site-specific seismic accelerations for a reference site class and for the response of the site-specific soil column.

8.6 EARTHQUAKE GROUND MOTIONS AS APPLIED TO ASSETS

8.6.1 The Offshore Platforms and Tanker Loading Unit (TLU)

The site-specific seismic design criteria of the American Petroleum Institute, Practice for Planning, Designing and Constructing Fixed Offshore Platforms (API RP2A) was used to establish the seismic criteria for both the Lunskeye and Piltun offshore platform sites (EQE, 1996b; ABSC, 2002). API RP2A recommends that two levels of ground motion shaking be considered in the design of fixed offshore structures. The first is a Strength Level Earthquake (SLE) defined as the ground motion which has a reasonable likelihood of not being exceeded at the site during the platform's life (associated with a recurrence interval somewhat longer than that used for wave design, taking into consideration the uncertainty in estimating ground motion and the differences between the performance requirements with wave versus earthquake design – typically a recurrence interval of 200 years for permanent structures in southern California). The second is a Ductility Level Earthquake (DLE) defined as the ground motion from a rare, intense earthquake (associated with an event controlled by the seismic environment that can have a recurrence interval of several hundred to a few thousand years). Project specific design criteria adopted a 200-year return period for SLE and a 3,000-year return period for DLE seismic design criteria.

For the Strength Level Earthquake (SLE), which has a reasonably low likelihood of exceedance during the life of the platform. The platform shall be designed such that it would sustain little or no damage during the SLE, but may require shut down and inspection subsequent to the occurrence of an SLE event. The SLE for all the offshore structures has a return period of 200 years, and equates to a peak ground acceleration (PGA) of approximately 0.1g.

For the Ductility Level Earthquake (DLE) which is a rare and intensive earthquake with a very low probability of exceedance during the life of the platforms. Structural elements are allowed to exhibit plastic deformation, but there shall not be unacceptable failures such as global collapse leading to loss of life or major environmental damage. The DLE for the offshore structures has a return period of 3000 years, and equates to a PGA of 0.38g for the platforms. The platforms are designed with Friction Pendulum Bearings on each leg (between the topsides and the substructure) to minimise the seismic loading to the PA-B and LUN-A Topsides.

For the TLU the DLE, PGA has been conservatively taken as 0.42g. The seismic loading is just one of many loads that must be borne by the structure (other loads include vessel contact, ocean currents, wave and wind). It should be noted that for the TLU, the seismic load is not the governing design load.

8.6.2 Onshore Processing Facility (OPF)

The design of the facilities for the OPF site is in accordance with Euro Code 8 ENV 1998 Design Provisions for Earthquake resistance of Structures. The reference return period (RRP) of the design earthquake is set at the 475 years and the design Peak Ground Acceleration (PGA) is 0.25g.

Normal industry practice, Eurocode 8 and the Russian SniP, only require the single level of earthquake in seismic design. To provide a sufficient margin of safety on the design PGA resulting of the RRP earthquake, the code requires the application of an Importance Factor. The Importance Factor for each structure is based on the function of the structure and the potential consequences of failure.

8.6.3 The LNG Plant, OET (Oil Export Terminal)

The LNG plant and adjacent OET site are located just east of the Mereya River on the northern coast of Aniva Bay near the settlement of Prigorodnoye and 18 km east of Korsakov (RSIS, 1998; Dames and Moore, 1998; Georisk, 2001). The onshore sites occupy the lower valleys of the Mereya River and Goluboy, Gremucheve and Vodopadnoye Creeks. The largest of these is the Mereya River that follows the south-southwestward structural trend of the region. The site area is covered by horizontally lying Quaternary deposits composed of alternating layers of sand, gravel and pebbles in the lower part of the soil column grading upwards to sandy loam, loam and clay soils at the top of the soil section. The horizontal Quaternary deposits overly the tightly folded and faulted Late Cretaceous claystones and siltstones of the Buikovski Formation.

Older faults in the region of the site were involved in pre-Quaternary deformation. Intermittent uplift in the mid-Quaternary is suggested by the occurrence of uplifted marine terraces, although some of the terraces are likely due to sea-level changes associated with Late Pleistocene glaciation (Dames and Moore, 1998; RSIS, 1998). Mapped and inferred faults exhibit no offset within the alluvium. Lineaments observed on satellite imagery correspond to mapped faults but none have sharp geomorphic or topographic expression typical of Holocene or Late Pleistocene surface displacements. The Vodopadnoye Brook fault in the vicinity of the OET site has evidence of young, but minor, geological displacement. This fault lies within 1 km to the east of the OET (Figure 8.10) and exhibits reverse movement with offset of less than about 0.5m. Radiocarbon ages of peat samples in the fault zone indicate that the latest movement took place no later than 3,700 years ago. Based on the observed offsets and extrapolation of the historical recurrence frequency curve for the area, the fault is judged capable of rupturing with a maximum magnitude of M_{LH} 6.5 with a recurrence frequency of approximately 4,500 years.

The seismic design of the LNG Plant is based on a distinction between the Strength Level Earthquake SLE and the Ductility Level Earthquake DLE. The SLE is the condition for which the complex will be designed: ie to withstand an earthquake without major damage such that the complex can be put back into operation after normal commissioning checks and/or minor repairs. The complex may suffer from trips and minor damage as a consequence of an SLE. The SLE is defined as an earthquake with an average return period of 475 years for which the PGA is 0.18g.

The DLE is the condition for which the design of specified units of the LNG complex, the LNG tanks including the LNG tanks will be verified to avoid catastrophic failure of the complex. Major loss of containment of hydrocarbons shall be avoided. For design purposes the SSE is defined as an earthquake with an average return period of 10,000 years. The PGA for this is 0.47g.

The design of the OET site will be carried out in accordance with Euro Code 8. The seismic design is to consider a design or effective PGA of 0.18g resulting from an earthquake with the Reference Return Period (RRP) of 475 years. The oil tanks will be designed to avoid catastrophic failure and major loss of containment of hydrocarbons for a DLE with a RRP of 5,000 years which corresponds to a PGA of 0.39g. Such a level of design means that, although the plant will have to shut down and undergo repair, there will not be a catastrophic release of oil.

8.6.4 Tsunami Hazard

Tide gauge data for southern Sakhalin Island has been collected at Korsakov for over 40 years (RSIS, 1998). Within that time, 30 mareograms of tsunamis have been recorded. The recording station is located within the harbour at Korsakov, which is protected from the open sea. The recordings, therefore, likely represent minimum tsunami heights. Flooding of the port area occurred from tsunamis in 1952 and from the great Chilean earthquake in May 1960. The 1952 tsunami event was caused by an earthquake located to the east of the Kamchatka Peninsula. Tsunami height in the harbour from mareogram recordings was 0.9 m. Tsunami height from the great 1960 Chilean earthquake was approximately 1.5 m. The precise height in the 1960 event cannot be determined as the recording extended to the end of the mareogram tape (RSIS, 1998). All other recordings of tsunami heights are considerably less than these two events. During the 43-year observation period, 24 tsunamis had recorded heights of more than 10 cm. This historical experience of moderate-to-low tsunami hazard suggests that Sakhalin Island is protected from severe tsunamis of the circum-Pacific region by the Kamchatka Peninsula and the Kuril Island chain that are located over 600 km to the east resulting in diminished tsunami energy within in the marginal Okhotsk Sea (RSIS, 1998).

Numerical tsunami models for two points at Ozersk (near Prigorodnoye) for different predominant periods ranging between 15 to 60 minutes suggest wave heights approximately 10% higher than at Korsakov due mainly to local subaerial topography. Calculated tsunami heights at Ozersk for return periods of 25, 50 and 100 years are 110, 165 and 220 centimetres, respectively. Shallow bathymetry at Ozersk and Prigorodnoye are identical and, consequently, the results for Ozersk are representative for Prigorodnoye.

All of the onshore facilities lie above the level of the expected height of any Tsunami.

8.6.5 Offshore Pipelines

Two offshore pipelines are routed eastward from the Piltun B Platform, then turn south for 35km to join with two pipelines from the Piltun A Platform. The four pipelines then continue a further 20km southwards before turning westward for 23km to the landfall (See Map 1). Faulting is observed on deep and shallow seismic data over the Piltun field, and although some faults approach very close to the seabed, the displacements are confined to Neogene and possibly Pleistocene sediments. Holocene sediments are undisturbed by faulting. There is no shallow faulting near the pipelines shoreward from Piltun A.

There are shallow faults in Neogene sediments over the Lunskeye field. These are faults that displace Neogene sediments but there are no young seabed displacements and no displacement in Holocene sediments.

At Aniva Bay, an oil export pipeline extends 5 km from the OET to the TLU and an outfall pipeline extends 1 km from the OET. Active tectonic faults were not found along the offshore pipeline routes (Saipem, 2003). Here, at Aniva Bay, the Vodopadnoye Brook fault cannot be traced offshore but in any event would lie to the east of the facilities and offshore pipelines. (See Map 3.)

Peak ground acceleration and velocity values were developed for return periods of 200 (SLE) and 2,000 (DLE) years in accordance with the design return periods in the PSTS (Project Specific Technical Specification). The PGAs typically range from 0.1 to 0.3g varying with the location along the route and the return period. The details are contained in the project documentation.

8.6.6 Onshore Pipelines

A pipeline buried in soil that is subject to the passage of propagating ground shear waves will incur longitudinal and bending strains as it conforms to the associated ground strains. In most cases, these strains are relatively small, and welded pipelines in good condition typically do not incur damage. Propagating seismic waves also give rise to hoop membrane strains and shearing strains in buried pipelines, but these strains are small and may be neglected.

Peak ground acceleration (PGA) and velocity values were developed for design for return periods of 200 (SLE) and 1,000 (DLE) years in accordance with the design return periods in the PSTS (Project Specific Technical Specification). The PGAs typically range from 0.1 to 0.4g varying with the location along the route and the return period. The details are contained in the project documentation.

8.6.7 Definitions Applying to Pipelines

The pipelines shall withstand the effect of a design Strength Level Earthquake, (SLE), earthquake without or with a minimal interruption of normal operation with no need for significant repairs.

The pipelines shall withstand the effect of a maximum Ductility Level Earthquake (DLE) without rupture. In this case a pipeline may be seriously affected, thus leading to a temporary cessation of operation with a need to perform repairs at one or several points.

8.7 LIQUEFACTION HAZARD

Liquefaction of granular soils or sediments is one of the major hazards to pipelines. Liquefaction does not occur randomly in natural deposits but within a rather narrow range of geologic and soil environments as summarized in Table 8.5. Sediments most susceptible to liquefaction are granular soils that remain loose and uncemented after deposition during recent geologic time (modern or late-Quaternary eras). Liquefaction occurs only in saturated sediments, i.e., sediments that lie beneath a shallow ground water table. There are many areas along the pipeline route where groundwater levels are near the ground surface.

These groundwater levels are sufficiently high to allow liquefaction in sediments that are susceptible to liquefaction.

Proximity to seismic sources also influences the likelihood of liquefaction. As described earlier, there are two main fault systems that affect the pipeline one, the Kliuchevskoi, that generally parallels the pipeline over its length and the other, the Goromai, with just a single pipeline crossing location, but which also parallels the pipeline for approximately 30 km. These faults are capable of generating earthquakes of sufficient magnitude to pose a liquefaction hazard for all areas underlain by liquefiable sediments.

The primary liquefaction-related hazard to pipelines is lateral spread of floodplain or shoreline deposits. Lateral spreading involves lateral movement of up to several metres of surficial (often-competent) soil layers underlain by liquefiable sediment. Depending on the depth of the liquefied soil, the surficial soil layer would slide down gentle slopes or toward a free face (e.g., an incised river channel or shoreline bluff). Lateral spread displacements may extend back as much as 100 m or more from river channels and create tensional features such as open fissures at the head (up-slope) of the failure, shear deformation along the margins, and compressional features such as buckling at the toe.

Lateral spread displacement is an important consideration for buried pipelines, because pipelines crossing zones of lateral spread displacement must deform longitudinally and in flexure to accommodate the ground displacement. If a pipeline crosses a zone of lateral spread displacement, it is necessary to delineate the length of pipeline exposed to ground displacement and the direction and distribution of lateral spread displacement relative to the pipeline alignment.

Other forms of liquefaction-induced ground deformation or failure affecting buried pipelines include flow failure, enhanced ground oscillations, buoyant rise, or ground settlement. The type and extent of ground failure depends on site geometry and the depth, thickness, and extent of the liquefied layer. Induced strains are generally lower for these effects than for the lateral spread hazard described above.

Table 8.5 Estimated Susceptibility of Sedimentary Deposits to Liquefaction during Strong Seismic Shaking (After Youd And Perkins, 1978)

Type of deposit	Distribution of cohesionless sediments in deposit	Likelihood that cohesionless sediments, when saturated, would be susceptible to liquefaction (by age of deposit)			
		< 500 yr	Holocene	Pleistocene	Pre-Pleistocene
(1)	(2)	(3)	(4)	(5)	(6)
(a) Continental Deposits					
River channel	Locally variable	Very high	High	Low	Very low
Flood plain	Locally variable	High	Moderate	Low	Very low
Alluvial fan and plain	Widespread	Moderate	Low	Low	Very low
Marine terraces and plains	Widespread	-	Low	Very low	Very low
Delta and fan-delta	Widespread	High	Moderate	Low	Very low
Lacustrine and playa	Variable	High	Moderate	Low	Very low
Colluvium	Variable	High	Moderate	Low	Very low
Talus	Widespread	Low	Low	Very low	Very low
Dunes	Widespread	High	Moderate	Low	Very low
Loess	Variable	High	High	High	Unknown
Glacial till	Variable	Low	Low	Very low	Very low
Tuff	Rare	Low	Low	Very low	Very low
Tephra	Widespread	High	High	?	?
Residual soils	Rare	Low	Low	Very low	Very low
Sebka	Locally variable	High	Moderate	Low	Very low
(b) Coastal Zone					
Delta	Widespread	Very high	High	Low	Very low
Estuarine	Locally variable	High	Moderate	Low	Very low
Beach/					
High wave energy	Widespread	Moderate	Low	Very low	Very low
Low wave energy	Widespread	High	Moderate	Low	Very low
Lagoonal	Locally variable	High	Moderate	Low	Very low
Fore shore	Locally variable	High	Moderate	Low	Very low
(c) Artificial Fill					
Uncompacted fill	Variable	Very high	-	-	-
Compacted fill	Variable	Low	-	-	-

8.8 MASS WASTING AND GROUND INSTABILITY HAZARDS

8.8.1 Area of Hazard

This section addresses geohazards arising from mass wasting, i.e. slope movement under gravity, and ground instability which, for the purposes of this part of the report, is defined as slope movement caused by surcharging loads and ground subsidence due to past mining activities. These hazards are essentially confined to the Makarov area of the onshore pipeline route, KP 340 to KP 464, see Maps 4 to 11. However due to a major re-route near Sovetskoye to avoid a number of faults, the pipelines pass through an area of steep terrain with some unstable slopes, KP 502-503. The one other area of steep terrain is around KP 45 to 60 but this area does not exhibit slope instability. The geomorphology at this location has been created by the underlying strong igneous rocks and presents no landslide or erosion hazard to the pipelines.

8.8.2 Geology and Geomorphology

Regional and local island geology has already been described in Section 1.2. In order to address matters of slope instability and movement in the Makarov area some further detail on the geological and geomorphological features along this part of the route is provided here.

In the Makarov area the character of the terrain is extensively controlled by the N-S strike of the bedrock, the materials comprising the bedrock and superficial deposits, and the particular tectonic events throughout the Cainozoic, which have resulted in extensive faulting and uplift. The latter has largely instigated a superimposed drainage pattern, draining eastwards as a result of control from the underlying N-S geological structure but with headwaters and tributary systems often feeding into the main watercourses at right angles.

The bedrock comprises shallow marine sediments, muds (clays and silts), sands of coarser grains with occasional limestone, together with some igneous (andesite and basalt) bodies. Several of the sedimentary horizons contain volcanic tuffs. These deposits have been lithified to weak to moderately strong sedimentary rocks and strong igneous rocks, which include the volcanic tuffs.

In the west of the Makarov region the rocks are of older Cretaceous age and contain considerable thicknesses of aleuolites (predominantly silty clays). Generally, the Cretaceous rocks are well-lithified and the aleuolites are over-consolidated to a stiff, fissured condition when fresh.

On the coastal side of the Makarov region, similar but younger materials exist of Cainozoic age that range from Oligocene to Miocene to Pliocene in the extreme east. These materials are again lithified but not so strongly as the Cretaceous and appear, from passing inspection and reference to the literature, to contain significantly fewer aleuolites. These sediments are often overlain by Quaternary age, unconsolidated sediments of shallow water, coastal and fluvial facies.

All the rocks and engineering soils show a weathering profile, with the depth of weathering varying from one to several metres, and are commonly overlain by a veneer of colluvial and/or taluvial materials, typically reworked soils and degraded

former river terraces, now elevated. The mantle may locally be subject to solifluction movement in cold weather.

The weathered bedrock material, together with the overlying materials, forms a *regolith* (i.e. a mantle) over the fresh bedrock. The engineering behaviour of the ground is largely governed by the characteristics of the regolith, a material highly variable in its geotechnical characteristics, often with unpredictable perched water tables. It is easily degradable and the great majority of the landslides and smaller instability features are in this material.

Fresh bedrock will only be encountered by the pipeline trench in locations where the trench is several metres deep, and/or at locations where the regolith has been removed or reduced by erosive processes.

The pipeline is routed through the Cretaceous rocks forming the western half of the Makarov area, i.e. much of the pipeline is over the landslide-prone aleuolite. The Cretaceous aleuolites provide the most extensive landslip covered terrain. The younger Cainozoic rocks east of the pipeline corridor, towards the coast, are not as markedly lithified, but are of stronger relief and appear to contain fewer aleuolite beds.

The aleuolites are particularly significant, in that they are a range of clay-rich soils/rocks very prone to mudslide and related types of failure. When fresh they are typically capable of standing at steep slopes for decades, but when weathered or frost-shattered they represent a rapidly degrading material, particularly when wet. They are also vulnerable to the erosive effects of streams and rivers, particularly when in spate. Aleuolites exhibit a variety of failure forms and much of the proposed pipeline alignment is directed through these materials.

The route in the Makarov area, south of the Makarov River, follows a south-westerly inland direction. This takes it into the area of Cretaceous rocks with their more subdued relief but greater thicknesses of high landslide-potential aleuolite, consequently presenting particular difficulties for a N-S pipeline alignment. The valley routes tend to encounter clay-rich materials, high water tables and old landslip areas; they are also particularly sensitive to ground freezing disturbance. On the other hand, the ridge routes are particularly prone to various types of instability, and require careful spoil management with due regard to environmental protection.

8.8.3 Seismicity

In all assessments of slope instability the local seismicity is taken into account. The appropriate accelerations are taken from the RSIS reports, which list the accelerations at a number of points down the route. Consideration is also given to the possibility of the initiation of liquefaction but this is generally not a significant hazard in the Makarov area due to the cohesive nature of the soils.

The consequences of seismic activity have also been considered in the analysis and design of mitigation measures for slope instability. Due regard is being taken of the possibility of seismic accelerations being focused on sections with sharp ridges and steeper slopes.

A review of the landslide hazards has been carried out by DJ Nyman & Associates in January 2001 following a field visit in October 2000. Their review takes the RSIS reports into consideration, along with field observations made during the visit. The report confirms the RSIS statement that 'future landslides along the pipeline route through the Makarov district are inevitable', and it includes a register of 21 landslide (geodynamic) sites, giving details of their width, depth, type, geomorphology and an assessment of current activity. With regards mitigation measures, the report supports the offshore re-route solution and goes on to make recommendations on how to proceed should the on-shore route be selected.

These recommendations can be summarised as follows:

- i) a detailed review of the RSIS data available;
- ii) aerial photography and mapping;
- iii) ground investigation along the proposed route;
- iv) field reconnaissance to identify routes which avoid the most dangerous landslide areas;
- v) geotechnical and slope stability analysis of landslide areas;
- vi) stress and deformation analysis of pipeline behaviour at landslide areas;
- vii) determination of construction methods to minimise triggering slides during construction.

Items i) to iv) above have already been carried out, and items v) to vii) are ongoing.

8.8.4 Ground Investigation

A series of ground investigations has been undertaken, commencing in 1998 and continuing up to and into the current construction period. The investigations fall into three discrete periods:

1998: DalTISIZ Institute, as part of a larger programme of survey work involving boreholes at regular intervals along the route to satisfy the SNiP requirements.

This investigation was carried out by hand excavations. The coordinate record indicates that it extended from KP 341 - 469 approximately.

2003:	Inzhzashchita	KP 322-362 (old), KP 339-379 approx (new) North
	DalGeo	KP 362-407 (old), KP 379-424 approx (new) Middle
	InzhGeo	KP 407-437 (old), KP 424-454 approx (new) South

The Inzhzaschita fieldwork was planned to include boreholes, inspection pits and geophysical surveys, but the ground conditions restricted the intrusive investigation to hand-dug pits.

For the middle section of the route the scheduled work was never reported due to subcontractor difficulties.

For the southern section of the route reporting was restricted to special reports for the two sites identified as Landslide No 1 and Landslide No 2.

2004: Inzhzaschita KP 322-442 (old), KP 340-464 approx (new)

This phase comprised intrusive (boreholes and inspection pits) and non-intrusive (geophysics) investigations. Interpretative and factual reports have been received consisting of 33 volumes. From these reports a Master Geohazard Register has been compiled for the Makarov.

The feasibility of the route through the Makarov was evaluated for SEIC by Scott Wilson, an international consulting practice, in 2001 and 2002. Further work was carried out by Scott Wilson jointly with the EPC Contractors geology/geotechnical team in 2004 to identify re-routes and to minimise exposure to geohazards. This work included aerial photograph interpretation, engineering geology and geomorphology field mapping, terrain classification and modelling. As part of SEIC's quality assurance programme on the project, Scott Wilson's role has been extended to provide technical support and supervision during the construction phase.

Inzhzaschita have been retained by Starstroi to execute the detailed design of the pipeline route through the hazardous areas. As part of the investigative work of Scott Wilson in the autumn of 2004, a programme of inspection trenches and trial pits was undertaken to obtain a better understanding of certain features. Due to access and logistic difficulties with the earlier investigations there are still areas requiring more detailed ground investigation to confirm, for example, existing failure plane depths. Consequently, further investigative work by means of trial pits to the required depth is underway; this investigative work will continue as necessary during the construction works. The current trial pit programme is attached in Appendix 8B. As the Right of Way is accessed, excavators are used to investigate down to the anticipated depth of failure surfaces in order to confirm the interpretation of geophysical investigation work and to establish parameters for foundation design, slope stability analysis, trench stability etc.

The geotechnical laboratory test data is often confined to the near-surface materials; the highly variable nature of the regolith soils and rock in the area over short distances is such that laboratory test data must be viewed with caution. Experienced judgement is necessary to interpret the data correctly as they may or may not be indicative of average and typical parameters for the soils. Where necessary, the effects of variation of the critical stability parameters are taken into account in stability assessments.

8.8.5 Geohazard Identification

Various reports have been produced that identify and describe the geohazards present on the Makarov section of the pipeline route – these reports are listed in References Section 8.10.

The geohazards fall into two categories, mostly natural, and some man-made (or man-induced). They can be in a state that is potential, incipient, active or dormant. It is inevitable that some will remain undetected by investigation, revealed only during construction - competent site supervision is being provided

to help in the detection of any geohazards not identified by earlier investigation work.

The natural geohazards comprise slope instability and movements in the form of erosion features, shallow solifluction, flows, and slides of varying depths. They are evident on the main parts of slopes and can also appear as run-out features and lobes in accumulation zones at lower levels in the valley floors.

Man-made geohazards have been brought about by the settlement, development and exploitation of the region. In the Makarov area the principal activities that impact on the pipeline route are earlier mining operations, the aborted construction of a N-S transportation route and current quarrying operations. There are also smaller scale features, including tracks, access roads, hillside terraces and small-scale cut/fill operations that locally interfere with the pipeline alignment. The man-made geohazards generally manifest themselves in the form of slope instability but, in the case of the mining legacy, they can also be expressed as potential ground subsidence and the modification of the surface and groundwater regimes.

The construction works themselves will generate man-made geohazards by the passage of construction plant, clearance of the RoW, excavation and backfilling of the trenches, inadvertent surcharging of adjacent slopes, and spoil disposal operations. Any of these activities could trigger movements, aggravate marginal ground conditions or re-activate previous instabilities. Design and supervision is being carried out to minimise these hazards.

The main hazards and their locations are shown on the topographic maps, Maps 4 to 11. The hazards range from mining-induced problems in the north (Krinka valley), moving southwards through extensive solifluction, landslides, and debris lobes (Pulka Valley) to narrow ridges and unstable, eroded fill (Lesnaya Ridge).

The contractor has produced a Geohazard Register covering all geohazards on this section of the project, KP340 to KP464. These hazards are categorized as

Geohazard	Risk Level	Mitigation
Level 1	Low	after construction using standard designs
Level 2	Medium	during construction using standard designs
Level 3	High	during construction using specific design

The Geohazard Register proposes a mitigation method that has to be approved by SEIC – There are 230 level 1 geohazards, 205 level 2, and 24 classed as Level 3 risk which require a full analysis and design submission to be approved prior to the work being included on construction alignment sheets. A spreadsheet of the Level 3 Risk Areas Design Control Sheet is shown in Appendix 8C, listing the areas which have or will have individual mitigation design carried out.

A series of typical drawings as follows has been produced to deal with the Level 1 and Level 2 hazards:

1. Bank Protection using Gabion Walls
2. Retaining Structures
3. Erosion Control Crossing and Drainage at Erosion Feature Crossings
4. Remedial Works for Avalanche Control
5. Erosion Protection of Cut Slopes
6. Mudflow Control Remedial Works
7. Bank Protection using Gabions and Mattresses
8. Drainage along the Pipeline Trench
9. ROW Erosion Protection
10. Watercourse Bank Protection using Geomesh
11. Watercourse Bank Protection using Stone Pitching
12. Erosion Barriers
13. Watercourse Bank Protection using Gabion Mattress
14. ROW Drainage Trench

For Level 3 hazards, re-routes are the preferred mitigation option in many instances. Failing that, complete excavation of the hazard is the secondary solution. Complex retaining works and drainage are the third choice solution.

8.8.6 Problematic Soil Conditions

No unusually problematic soils have been identified in the Makarov area or elsewhere on the route.

8.9 MITIGATION MEASURES FOR PIPELINES

8.9.1 Crossings of Active Faults

As described in earlier sections, the route of the pipelines passes through active seismic zones and crosses active faults having the capability to produce rupture of the ground surface. Fault crossings represent a significant hazard for a buried pipeline, because if surface rupture occurs during a seismic event, it would be necessary for the pipeline to accommodate significant differential ground displacement across the fault zone.

There are two faults crossed by the pipelines. There is one crossing of the Goromai Fault and 18 crossings of the Kliuchevskoi Fault. This latter fault runs generally parallel to the Sakhalin II pipeline route over most of its length. During the years of development of the project a number of potential crossings have been avoided by re-routing. However due to constraints from settlements and existing roads and utility corridors there is no further scope for reduction. The 19 crossings and their displacements are summarised in Table 8.6.

A buried crossing mode is normally preferred, because it avoids technical issues associated with a long run of unrestrained pipe, and it limits exposure to third-party damage. The usual design approach for pipeline fault crossings is to construct the pipeline in a shallow, sloped-wall trench with loose backfill to promote flexibility of the pipeline within its soil encasement. However, perennial winter frozen soil conditions on Sakhalin dictate the need for consideration of special backfill of lightweight manufactured granular materials and polyethylene foam. These materials are the subject of a testing programme in the laboratory for physical properties. Laboratory scale tests of the material surrounding a model pipe at 1:8 and 1:4 scale are underway to verify the design concept. Notwithstanding this there may be one or two crossings that, as a last resort, may have to be above-ground because of land constraints forcing unfavourable fault crossing angles. It should be noted that 8 faults, faults 10 to 17, are hanging wall faults with relatively small strike-slip movements that are easily accommodated by a well designed welded pipeline.

Table 8.6 Summary of Fault Displacement Components

No.	Name	Faulting Style	Approx. KP	Fault Displacements from ABSC Table			
				V ⁽¹⁾	S ⁽²⁾	T ⁽³⁾	Total
1 Alt	Goromai	RL Oblique	15	1.0	5.4	0.13	5.5
3	Kliuchevskoi	Reverse	118	2.3	N/A	2.3	3.3
4	Kliuchevskoi	Reverse	180	2.1	N/A	2.1	3.0
5	Kliuchevskoi	Reverse	186	2.5	N/A	2.5	3.5
6	Kliuchevskoi	Reverse	189	0.7	N/A	0.7	1.0
7	Kliuchevskoi	Reverse	209	2.0	N/A	2.0	2.8
8	Kliuchevskoi	Reverse	224	2.0	N/A	2.0	2.8
9	Kliuchevskoi	Reverse	301	2.0	N/A	2.0	2.8
10	Gastello	LL Oblique	302	1.0	-0.5	0.0	1.1
11	East Makarov	RL Oblique	343	0.5	0.5	0.0	0.7
12	East Makarov	RL Oblique	343	0.5	0.5	0.0	0.7
13	East Makarov	RL Oblique	343	0.5	0.5	0.0	0.7
14	East Makarov	RL Oblique	343	1.0	1.0	0.0	1.4
15	West Makarov	RL Oblique	347	1.5	1.5	0.0	2.1
16	Chernaya River	LL Oblique	481	0.5	-0.5	0.0	0.7
17	Kirpichnaya River	RL Oblique	493	1.0	1.0	0.0	1.4
18 Alt	Kliuchevskoi	Reverse	509	2.7	N/A	2.7	3.8
20	Kliuchevskoi	Reverse	567	3.0	N/A	3.0	4.2
21	Kliuchevskoi	Reverse	569	3.0	N/A	3.0	4.2

Notes:

1. V = vertical fault displacement
2. S = strike fault displacement (parallel to fault) with positive values indication right-lateral slip
3. T = transverse fault displacement (perpendicular to fault) with positive values indicating contraction across fault. For reverse faults this is derived from the vertical displacement and the fault dip of 45°, T=V for this dip.

8.9.2 Analysis Methodology

Large strains and permanent deformation of the pipelines are permissible in the extreme event of fault displacement, provided that pressure boundary integrity is maintained. The methodology for assessment of pipelines subjected to large ground deformations is described in two state-of-the-art guidelines, a seminal document prepared by ASCE (1984) followed by an updated and improved guideline prepared for the Pipeline Research Council Incorporated (PRCI) by Honegger and Nyman (2004). These documents are being followed in the analyses of all of the crossings.

The analysis of a buried pipeline subjected to surface fault rupture accounts for inelastic pipeline behaviour, the nonlinear behaviour of the surrounding soil mass, and large displacement effects. Soil-pipeline interaction is modelled with discrete nonlinear springs oriented in the axial, horizontal, and vertical directions. The methodology for calculating soil springs is well-established (ASCE, 1984; ALA, 2001). Fault displacement is applied to the model as displacements of the base of the soil springs on one side of the fault as shown in the idealised model in Figure 8.13. The definition of soil (spring) restraint properties must be consistent with field conditions. In particular, for displacement of the pipeline in a transverse horizontal direction, the soil failure wedge must be enveloped by the limits of the excavated pipe trench that is backfilled with the selected material. The trenches will be dug to the appropriate size to ensure this can happen. Similarly, for vertical displacement, the upward breakout will occur within the designated backfill.

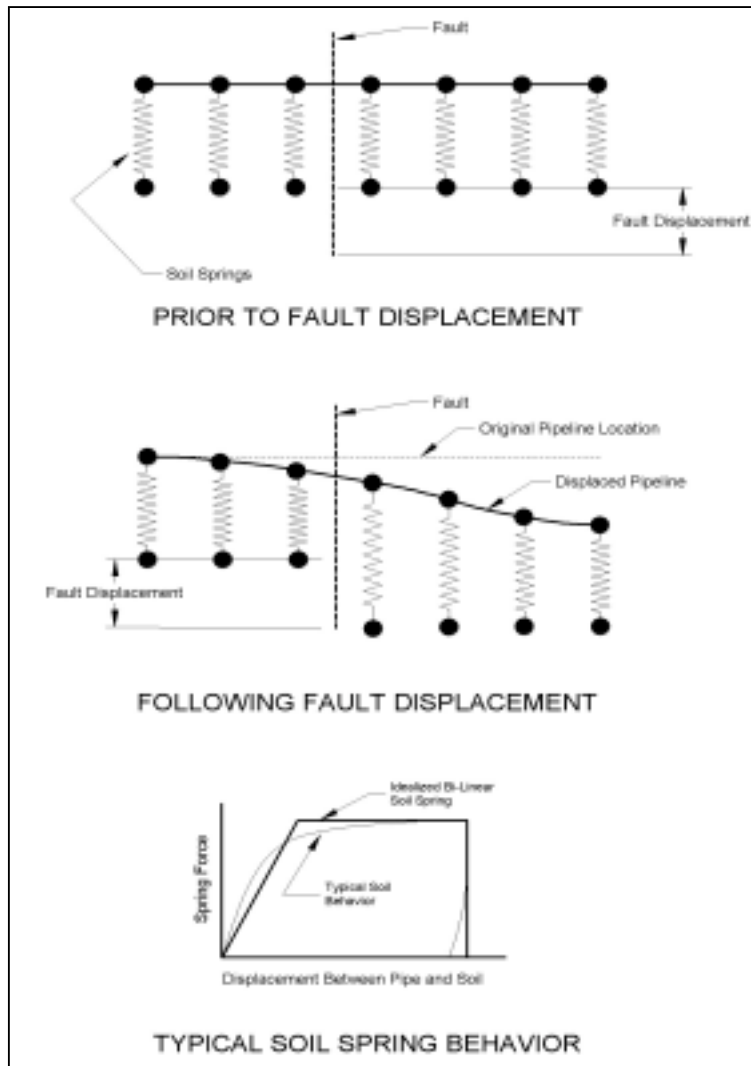

Figure 8.13. Soil spring characteristics used to represent soil restraint.

Fault Displacement Components

Ground displacement at a fault is defined in terms of the strike (fault-parallel), compressional (fault-perpendicular) and vertical components of fault displacement. The components of fault displacement are defined based on the style of faulting and the azimuth of the fault relative to the azimuth of the regional geologic principal stress. In accordance with the clarification provided by ABS, the fault displacement components for reverse-slip faults are determined in the following manner:

1. A horizontal component of fault displacement is assumed to be equal to the vertical fault displacement, consistent with an effective dip angle of 45°, and acting in the direction of the regional principal stress azimuth, estimated by ABS to be 70° (or a bearing of N70°E);
2. The strike and transverse components of fault displacement are determined as the cosine and sine, respectively, of the angle between the local¹ fault azimuth and the regional stress azimuth.

The regional stress concept does not apply to strike-slip or oblique slip faults; thus, the tabulated fault displacements are used for these faults which implies a near-vertical dip angle.

Analyses have been carried out to investigate the most favourable crossing angles for the different style of faults and these have led to the conclusion that the pipeline azimuth should lie somewhere between 126° and 194°. Local re-routing of the pipelines at the crossings has been made to take advantage of the most favourable crossing angles particular to the local circumstances.

Pipeline Strain Criteria

A pipeline responding to fault displacement experiences soil loads generated by ground movement relative to the pipeline. The pipeline experiences no further soil load once it has deformed sufficiently to match the ground movement. This type of loading is commonly referred to as being displacement-controlled. For pipelines experiencing displacement-controlled loading it is appropriate to base the design on strain limits as opposed to stress limits.

Strain limits for determining the fault displacement capacity of the pipelines are based on allowing yielding and distortion of the pipe wall whilst maintaining pressure boundary integrity. In other words, failure in a strain-based design is taken to mean loss of pressure boundary integrity and strain levels and deformations can be such that the pipeline may require some repair. Fault displacement is a very low probability event over a design pipeline lifetime of 30 years given the field evidence gathered that indicated that ground breaking fault displacements have return periods of hundreds of years for the faults of concern to the pipelines.

¹ The local fault azimuth is the orientation of the fault rupture scarp at the location of the pipeline crossing. Reverse faults typically change direction as they wrap around topographic relief features.

There is extensive successful experience with highly strained welded line pipe installed from reel barges for subsea pipelines in diameters up to 457 mm (18 inches). Nominal bending strains (tensile and compressive) in the coiled pipe on the reel are on the order of 2%, and only infrequent failures have been reported. For new pipelines constructed of moderate strength pipe steel using welding and inspection specifications similar to those used in offshore applications, tensile strain capacities of 4% prior to loss of pressure integrity are generally achievable.

Full-scale combined axial compression and bending tests and supplementary finite element analyses have been conducted by various universities and test organisations. The maximum strain attained in these tests has been mined from publicly available papers and reports and plotted against the diameter-to-thickness ratio, D/t (see Nyman et al., 2003). The results support the approach that the limiting strains used on the project are well below rupture level.

Welding and Weld Inspection

Strain acceptance limits are based on the assumption that the pipeline girth welds will be capable of developing gross section yielding of the pipe wall. This capability, often referred to as “overmatching welds”, means that failure would occur in the pipe before failure in the weld or the weld heat affected zone. This implies that the weldment will have a higher tensile strength than the pipe.

Appropriate steps are being taken to ensure overmatching by the development of appropriate weld procedures. Specialised non-destructive testing of all welds for the pipeline in the fault crossing zone will be carried out as required to ensure the integrity of the welds to meet the overmatching criterion.

Summary of Fault Crossing Design Concept

The current state-of-practice for pipeline fault crossings of constructing the pipeline in a trench with shallow-sloped walls with loose granular backfill to facilitate transverse and vertical upward displacement of the pipeline within the backfill in response to abrupt fault rupture offsets is being followed. The pipeline is allowed to experience large strains and permanent deformation, provided pipe rupture can be prevented. The risk of damage requiring repair is deemed acceptable provided that pressure integrity is maintained (i.e., rupture and leakage of contents is prevented). Specific considerations for the potential frozen ground conditions are being evaluated by analysis and laboratory testing. The pipelines accommodate the displacements by moving laterally and vertically out of the trench.

The frozen ground condition can be accommodated through several approaches that are presently under study:

- Provision of a layer of insulation to limit the loss of heat to the atmosphere, thus preventing the soil from freezing. Drainage of the backfill is to be provided to limit the effect of some freezing that might occur;
- Use of geosynthetic wrap around the pipeline to reduce the axial pullout restraint of the soil surrounding the pipeline;

- Use of non-frost susceptible lightweight aggregate, such as sintered fly ash, as backfill. This backfill would have lower soil restraint due to its lower unit weight and would have less susceptibility to freezing action;
- The use of polyethylene foam blocks or other materials that will either crush or move laterally on a geotextile-lined failure surface to permit pipe displacement. For example, polyethylene has been used behind retaining walls and on slopes because of its low gravity weight and, hence, low driving forces from a stability standpoint;
- The use of bend offsets (“doglegs”) to reduce compressive force in the pipeline that leads to high strain and possibly upheaval buckling. Compressive force is reduced through deformation of the pipeline at the bend offsets (analogous to an expansion loop);
- As a last option, the use of above-ground pipeline configurations to accommodate large fault displacements. Above-ground concepts have the advantage of being less sensitive to crossing alignment provided the pipeline has offsets or “zig-zags” to permit thermal expansion and fault offset displacement parallel to the pipeline centreline.

Schematics of the dog-leg configuration and the trench with granular backfill and insulation are shown in Figures 8.14 and 8.15.

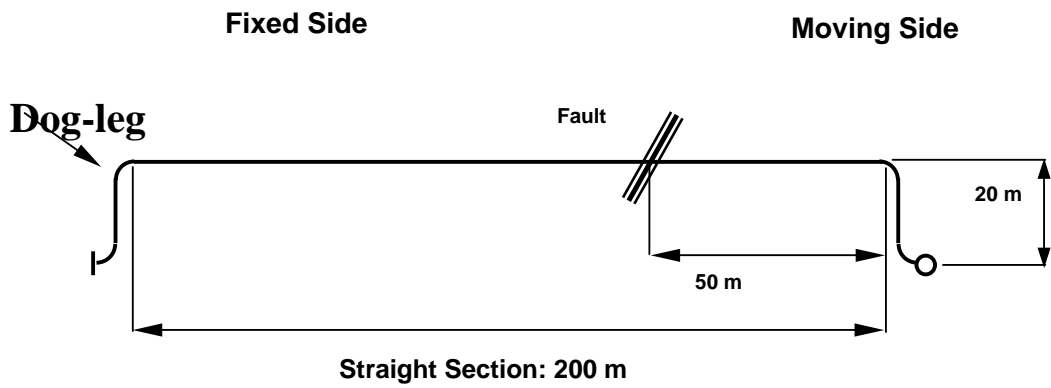

Figure 8.14. Schematic of Dog-leg configuration across a Fault

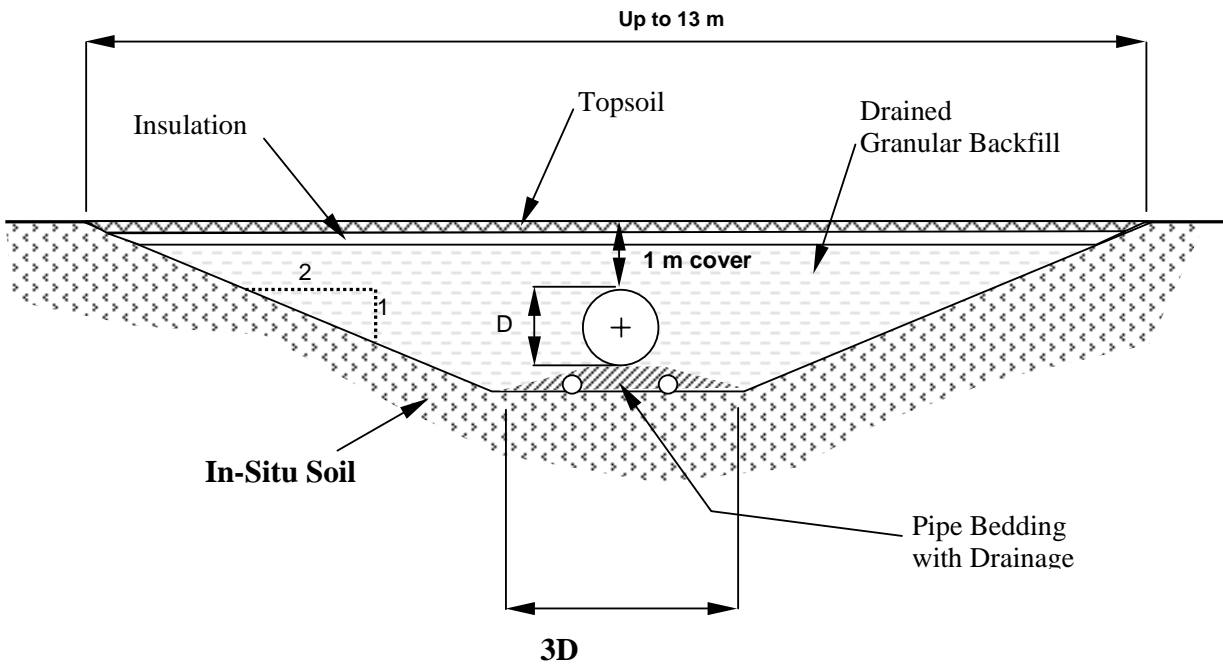

Figure 8.15. Schematic Diagram of Trapezoidal Trench Cross Section

8.9.3 Seismic Ground Motion

Wave Propagation Effects on Pipelines

A simplified approach to estimating ground strain is provided in ASCE (1984). This approach was reviewed and incorporated into recent guidelines (ALA, 2001) by an ASCE/ASME working group sponsored by the American Lifelines Alliance. Buried pipelines experience transient strains as the result of the pipeline conforming to the ground strain created by wave propagation. Pipe strains from wave propagation are similar to other permanent ground deformation (PGD) hazards because the pipe response is displacement limited. That is, the strain in the pipe is limited by the ground strain. The acceptable tension and compression strain limit for pipelines responding to seismic wave propagation is 0.5%. Well-constructed buried oil and gas pipelines in good condition generally have not been affected by seismic wave propagation. This is borne out by the lack of a single reported case of failure of ductile, full penetration welded oil or gas pipeline attributable to wave propagation alone. Recent earthquake experience (Honegger, 1999) has indicated that wave propagation is a credible earthquake hazard for pipelines only in cases of extremely poor quality girth welds or corrosion defects subjected to very high levels of seismic ground motion.

Ground Shaking Effects on Above-Ground Facilities

Earthquake ground shaking will cause seismic dynamic loading of above ground pipeline facilities. Typical facilities for the Sakhalin II pipelines include buildings, structures, vessels, liquid storage tanks, piping, mechanical and electrical equipment, control systems, instrumentation, and communications. The seismic design of pipeline facilities follows typical building code approaches, e.g., the Uniform Building Code (UBC) (ICBO, 1997) and its recent replacement, the International Building Code (ICC, 2003). Attention will be given to assuring the operational integrity of systems that provide essential monitoring, control, safety, and emergency functions. Examples of critical components include monitoring instrumentation, communications equipment, computer hardware, remote valve auxiliary equipment, emergency power systems, and uninterruptible power supplies.

8.9.4 Liquefaction

The assessment of liquefaction hazards along the pipeline route used a systematic screening process. Geologic criteria were applied as a first step to identify locations where deposits that are susceptible to liquefaction may be found. Along the Sakhalin II pipeline corridor, these deposits occur primarily at river and stream channels and at the landfalls. If the geologic criteria indicated that a river channel or other area was non-liquefiable, the crossing or area was classified as non-hazardous and the screening was completed. A programme of SASW testing (Spectral Analysis of Surface Waves) was carried out at these types of areas in 2001. If the geologic screening indicated a possible liquefaction hazard, then a geotechnical engineering review of borehole and where available CPTs was completed to assess liquefaction resistance of the sediment. In the geotechnical review, recognised procedures to assess the potential for liquefaction to occur were used. Where subsurface data was limited or not available, logical and reasonably conservative assumptions were made based on

the geologic setting of the site under consideration. The EPC contractor has supplemented previous information with a programme of Cone Penetration Tests (CPTs) in 2004.

Based on these data the liquefaction potential along the route has been assessed and the areas that might be at risk and are to be considered for mitigation have been identified. Liquefaction hazard areas are tabulated in Appendix 8A

In Segment 1, the zones at high risk represent a relatively large percentage of the pipeline route. This is due to the prevalence of saturated sandy formations in this area, combined with high values of PGA.

In Segment 3, the amount of the pipeline route crossing liquefaction hazard areas is much lower. They are, in general, limited to areas around riverbeds or old meanders (recent loose alluvial deposits).

Flow Failure

Flow failure is the most catastrophic type of permanent ground deformation caused by liquefaction. Flow failure occurs on steeper slopes (greater than 6% or 3.5) underlain by loose liquefiable soils. Flow failures are characterized by large lateral displacements (several meters or more) and severe internal disruption of the failure mass. Structures founded upon or within the mobilized soil are usually severely damaged and often fractured and displaced. However no areas along the Sakhalin II pipelines route with liquefiable deposits resting on slopes greater than six percent have been identified. Local flow failures could occur in steep riverbanks, but this is mitigated by the depth of burial of the pipeline river crossings.

Lateral Spread

Lateral spread displacements at potential liquefaction hazard areas were estimated using a regression equation based upon a statistical database of worldwide observations of liquefaction occurring during major earthquakes (Youd et al, 2002). The regression equation applies to two general conditions: "free-face" conditions, meaning a steeply sloping embankment such as the bank of a river or stream, and gently sloping ground.

The lateral spread hazards at river crossings are mitigated by crossing the river with an alignment that minimises transverse displacement while taking full advantage of the pipe capacity to withstand ground displacement parallel to the pipeline. In addition, the pipeline will be placed below the zones of largest lateral spread movement to avoid the highest ground deformation strains.

For river and stream crossings containing liquefiable sediments, the pipeline will be constructed to pass under the river channel in a horizontal plane at an elevation such that the minimum vertical distance between the bottom of channel and top-of-pipe is 1.5 m. This depth will be normally maintained for a distance of 30 m beyond the channel banks, after which the pipeline would transition on a 1:10 slope to a normal depth of burial.

In the analysis of the hazard the important input factors are the distance from a fault and the magnitude of earthquake on that fault. As recommended in ABSC Memorandum 2005 based on deaggregation analyses of the ground motion

hazards, the magnitude is taken conservatively as M_w 6.5 everywhere along the pipeline route. The actual distance to the fault from the point on the pipeline route being evaluated is used up to a maximum of 30 km. Any points further than 30km are assigned a distance of 30km which effectively equates to a minimum PGA of 0.11g.

Nonlinear finite element analysis, similar to that performed for fault crossings will be performed for enveloping crossing conditions to validate pipeline performance against project specific strain criteria. Pipe and welds will be selected for high strain performance.

Buoyant Rise

Pipelines and other lightweight buried structures may buoyantly rise when the surrounding soil liquefies. In most instances along the Sakhalin II pipeline route, well-fabricated steel pipelines can accommodate some rise, especially if distributed over a large length of the line, without exceeding the flexural strength of the pipe. Where mitigation is necessary, the following measures are being implemented:

- Surrounding the pipe with non-liquefiable backfill;
- Embed the pipeline beneath the liquefiable layer to avoid all of the hazards associated with liquefaction;
- Use concrete weights as used in standard floodplain and marsh construction to provide adequate ballasting against buoyant rise.

8.9.5 Ground Instability and Landslides

8.9.5.1 Mitigation Options

The broad range of geohazards have been described in earlier sections. Mitigation measures fall into four groups as follows

- Avoidance by re-routes or by hazard removal;
- Ground works (treatment, reinforcement, load transfer, retention);
- Surface protection;
- Drainage.

Re-routes are the simplest engineering solution and these have ranged from less than 100m up to kilometres in length. However, in many situations re-routes are not practicable and recourse has to be made to other measures. Table 8.7 below shows potential hazards and possible mitigation measures - this provides the contractor with a guide to the mitigation measures available, which can be related to standard details. This table can be used as an aid to design assessment and cost evaluation, along with identification of locations where special non-standard details are required.

Table 8.7: Potential hazards and possible mitigation measures

Hazard Category		Mitigation Measures	
Natural Instability	1A Headward Erosion 1B Solifluction 1C Landslide Flow 1D Landslide Slide 1E Block Slide	Avoidance	1a Re-Route 1b Deepen 1c Increase Pipe Separation 1d Decrease Pipe Separation 1e Watercourse Diversion
Potential Instability	2A Narrow Ridge 2B Steep Sidelong Ground 2C Made Ground 2D Spoil Handling, Disposal	Ground Works	2a Dig out / Replace 2b Compaction 2c Soil Nails 2d Benched Embankment 2e Gabion / Crib Wall 2f Concrete Retaining Wall 2g Sheet Piles 2h Backfill 2j Spoil Retention Barriers
Construction Related	3A Soft Ground 3B Rock Excavation 3C Watercourse Crossing 3D Watercourse Proximity 3E Mining Legacy	Surface Protection	3a Check dam 3b Bio-Engineering 3c Gabion Netting / Mats 3d Shotcrete
		Drainage	4a Surface Drains 4b Deep Drainage

8.9.5.2 Monitoring and Construction Inspection

The design process must give consideration to the need for monitoring at difficult hazard locations which cannot be avoided by re-route of the pipeline. Monitoring devices may include but not necessarily be limited to the following:

- Surface markers, embedded shallow rods, with precise surveying;
- Inclinometers;
- Piezometers;
- Tiltmeters;
- Strain measurement gauges (ground and/or pipeline);
- Acoustic emission monitors;
- Fibre optics.

The Contractor is required to produce a geohazard manual for use after the pipeline has been commissioned, which will detail any monitoring and inspection procedures and provide advice on the interpretation of data, particularly in respect of trigger levels for taking appropriate actions to safeguard the pipelines.

8.9.5.3 Illustrative Locations

As an illustration of the nature of some of the geohazards encountered and their potential respective mitigation measures, two areas are briefly discussed. Firstly, the Krinka valley, with its legacy of earlier coal mining and, secondly, the Pulka valley with its variety of unstable slope forms.

Krinka

This site is shown on Map 4 and is located towards the north end of the Makarov section. The geology comprises thinly bedded to laminated muddy siltstones and siltstones, locally carbonaceous, with some thin to moderate coal beds and occasional moderately thick sandstones. The beds are near-vertical in attitude, so that the differential erosion between the stronger sandstones and weaker argillaceous materials results in localised ridge formations with a broadly N-S orientation.

The original alignment crossed a large mudflow running eastwards down from a former opencast mine to the bank of the River Krinka. This feature originated from a spoil tip adjacent to the excavation but also appears to have carried with it some natural ground. At its head an impounded lake has been created by the mining excavation and damming effect of the spoil. The mudflow material is estimated to be several metres deep, with a high probability of further ground movement in this area. It was concluded that the original alignments presented difficulties that would be impossible to overcome without very considerable and costly engineering works together with long-term and demanding maintenance commitments.

Consequently, the Contractor proposed a re-route to the west, climbing to higher ground above the impounded lake and its bordering "high wall" to the former

opencast site. Scott Wilson also explored and identified a second possible re-route a little further to the west, refer to Map 1, but the Contractor elected to remain with his first choice. This re-route has been provisionally accepted by SEIC, subject to further investigation by trenching and design, by the Contractor, to demonstrate its viability. This further work includes investigation and assessment of:

- Ground conditions along the re-route;
- Apparent mineworking features, i.e. ground depressions;
- Design measures to deal with steeply dipping, differentially weathered beds aligned obliquely to the route and affecting the approach ridge;
- The security of the “high wall”;
- The risk of further movement of the existing mudflow, blocking/breaching and subsequent scouring of the River Krinka, together with release of the impounded lake and drawdown effects;
- General revetment works to the River Krinka and the next stream crossing to the south, together with the stabilisation of adjacent slope movements.

In summation, the mitigation measures in this area will encompass significant works within all four-named categories on the matrix, i.e. avoidance, ground treatment, surface protection and drainage.

Pulka

This site is also shown on Map 4 located a little way south of the Krinka valley.

The Pulka River runs roughly N-S down an asymmetrical valley composed of a western dip slope and an eastern scarp slope. The alignment follows a course either along the western slopes or the valley bottom. The geology comprises bedrock composed of easterly dipping Pliocene-Miocene age interbedded mudstones and sandstones. No bedrock has been recorded on the western slopes or stream sections. Outcrops on the eastern slopes are of mixed argillaceous and arenaceous character. The western lower valley slopes appear dominated by coarse superficial deposits, probably of river terrace origin and a flatter, alluvial flood plain occurs on the lower ground below the upper terraces. The western slope terraces, probably reworked coarse colluvium/scree, may have been eroded, transported and deposited during a much wetter climatic period within the Pleistocene.

The surface of the terraces/fans is frequently hummocky and shows signs of movement. This is unlikely to be deep-seated and is most likely a freeze-thaw near-surface downward creep. There is a significant spring line at the base of the upper terrace deposits. A shallow slip area was noted, being probably a relict feature. Aerial photography interpretation and field verification confirmed the presence of landslide deposits and debris flow deposits derived from the tributary catchments above. Most of these deposits are fairly subtle and it is judged likely that active movement is only regularly taking place in the upper soliflucted layers.

An alternative re-route has been proposed to take the pipeline away from the terrace fronts and possible hazard areas identified by the aerial photography interpretation but this would take it onto the wetter alluvial flood plain. The practicalities and hydrogeological/environmental implications of taking the route along the lower part of the valley in proximity to the river are currently being examined.

This section of the route follows a corridor sensitive in both geotechnical and environmental terms. Mitigation measures will be implemented and are likely to comprise a combination of local re-routes, ground treatment, surface protection and drainage works.

8.9.5.4 Soil Conditions

As there are no problematic soils in this area, no special mitigation or monitoring measures are required.

8.10 REFERENCES

- Abrahamson, N.A. and W. Silva (1997) Empirical Response Spectral Attenuation Relations for Shallow Crustal Earthquakes. *Seismological Research Letters*, Vol. 68, p. 94-127.
- ABSC [EQE] (2000) Validation of State Association Fault Studies Along the Trans-Sakhalin Island Pipeline Route and Development of Fault Displacement Parameters for Engineering Applications. *Report Prepared for Marathon Upstream Sakhalin Services, LTD.*, 81 p. + Appendices.
- ABSC (2002) Seismic Hazard Reassessment of the Piltun, Lunskeye, and TLU Offshore Sites, Sakhalin Island, Russia. *Report prepared for AMEC Offshore Services Limited*, by ABS Consulting, Lakewood, Colorado, 99 p.
- ABSC (2003). "Seismic Hazard Sensitivity Testing Results", *Report prepared for Sakhalin Energy Investment Company, Ltd.*, by ABS Consulting, Lakewood, Colorado, 15 p.
- ABSC (2005) Review and Resolution of Active-Fault Geological Displacements for the Sakhalin II Export Pipeline Project. *Report prepared for Sakhalin Energy Investment Company, Ltd.* by ABS Consulting, Lakewood, Colorado, 130 p plus Appendices.
- ALA (American Lifelines Alliance) (2001) Guidelines for the Design of Buried Steel Pipe, G.A. Antaki and J.D. Hart, Co-Chairmen, July, 76 p.
- Apel, E V, R. Burgmann, M. Mikhail, R. King, N.F. Vasilenko, V.I. Levin, G.M. Steblov, D.I. Forlov, A.I. Ivaschenko, and Y.I. Gordeyev (2004) Active Tectonics of Northeast Asia: Using Block Modelling to Test Okhotsk Plate Motion Independent from North America, *Abs Eos. Trans. AGU, Vol. 85, No. 28, Western Pacific Geophysics Meeting Supplement, Abstract T344A-06.*
- ASCE (American Society of Civil Engineers) (1984) Guidelines for the Seismic Design of Oil and Gas Pipeline Systems. *Technical Council on Lifeline Earthquake Engineering, Committee on Gas and Liquid Fuel Lifelines*. New York, 473 p.
- American Society of Mechanical Engineers (1992) ASME B31.1 – Power Piping, Appendix VII, Non-mandatory Procedures for the Design of Restrained Underground Piping.
- Ben-Avraham, Z., and Uyeda, S. (1983) Entrapment Origin of Marginal Seas, *in* T.W. Hilde, and S. Uyeda (eds) *Geodynamics of the Western Pacific-Indonesian Region*, *AGU/GSA Geodynamics Series*, Vol. 11, p. 413-422.
- Besstrashnov, V.M. and A.L. Strom (1998) Traces of Prehistoric Earthquakes Along the Hokkaido-Sakhalin Fault, Northern Sakhalin. *8th International IAEG Congress*, Balkema, Rotterdam, p. 697-702.
- Besstrashnov, V.M., H. Goto, G. Kimura, A.I. Kojurin, K. Okumura, M.I. Streltsov, A.L. Strom, Y. Suzuki, H. Tsutsumi, T. Ueki, and H. Watanabe (1999) Evidences of Strong Past Earthquakes Along the Major Sakhalin Faults: Implications for Seismic Hazard. *Journal of Geology, Series B*, No. 13-14, p. 287-291.
- Bulgakov, R.F., A.I. Ivashchenko, Ch. U. Kim, K.F. Sergeev, M.I. Strelt'sov, A.I. Kozhurin, V.M. Besstrashnov, A.L. Strom, Y. Suzuki, H. Tsutsumi, M. Watanabe, T. Ueki, T. Shimamoto, K. Okumura, H. Goto, and Y. Kariya (2002) Active Faults in North-eastern Sakhalin. *Geotectonics*, Vol. 36, No. 3, p. 227-246.

Campbell, K.W. (1995) Preliminary Empirical Assessment of Near-Source Ground Motion From the *Mw* 6.7 Northridge, California, Earthquake of January 17, 1994. *Seismological Research Letters*, Vol. 66, 2, p. 27.

Dames and Moore (1998) Seismic Hazard Assessment for Proposed LNG Terminal and Adjacent Oil Terminal at Prigorodnoye, Aniva Bay, Sakhalin Island, Russia.

D J Nyman & Associates (2001) Review of Earthquake –Induced Landslide Hazards, Sakhalin Pipeline.

EQE (2000) Validation of State Association ‘Rosstroizyskaniya’ Fault Studies Along the Trans-Sakhalin Island Pipeline Route and Development of Fault Displacement Parameters for Engineering Applications. *Report Prepared for Marathon Upstream Sakhalin Services Limited*, 81p. + Appendices.

EQE International, Inc. (1996a) Seismic Hazard Assessment of Selected Oil and Gas Facilities on Sakhalin Island, Russia, Phase 1: Seismotectonic Characterization. *Report prepared for Sakhalin Energy Investment Company, Ltd.*, Yuzhno-Sakhalinsk, Sakhalin Island Russia, and Exxon Neftegas Ltd., Houston, Texas, by EQE International Inc., Evergreen, Colorado.

EQE International, Inc. (1996b) Seismic Hazard Assessment of Selected Offshore and Onshore Oil and Gas Facilities on Sakhalin Island, Russia, Phase 2: Seismic Design Criteria for the Piltun-Astokhskoye, Lunskeye, and Katangli Facility Sites. *Report prepared for Sakhalin Energy Investment Company, Ltd.*, by EQE International Inc., Evergreen, Colorado.

FGUP Rosstroyizyskaniya, Inzhzhaschita LLC. (2004) Interim Report as per Results of Engineering Survey: Design and Construction of Export Pipelines at landslide Areas of Third and Fourth Construction Spreads from Kp 341 to Kp 381.

Fournier, M., L. Jolivet, P. Huchon, K.F. Sergeyev, and L.S. Oscorbin (1994) Neogene Strike-Slip Faulting in Sakhalin and the Japan Sea Opening. *Journal of Geophysical Research*, Vol. 99, p. 2701-2725.

Georisk (2001) Edition and Compilation of the Second Version of the Report and Materials on Seismic Microzoning of the LNG Plant Site, Object Sakhalin-2.

Goodling, E.C. (1991) Restrained Underground Piping – Some Practical Aspects of Analysis and Design. *Proceedings of the Third U.S. Conference on Lifeline Earthquake Engineering, Technical Council on Lifeline Earthquake Engineering Monograph No. 4, American Society of Civil Engineers*, pp. 395-404.

Hadjian, A.H. and D.M. Hadley (1981) Studies of Apparent Seismic Wave Velocity. *Proceedings of the International Conference on Recent Advances in Geotechnical Earthquake Engineering and Soil Dynamics, American Society of Civil Engineers*.

Honegger, D. G. (1999) Assessment of Wave Propagation Effects on a 1925 Pipeline with Oxyacetylene Girth Welds. *Proceedings of the 5th National Conference on Lifeline Earthquake Engineering, American Society of Civil Engineers*, August.

Honegger, D. G., and D. J. Nyman, (2004) Guidelines for the Seismic Design and Assessment of Natural Gas and Liquid Hydrocarbon Pipelines. *Report prepared for the Pipeline Design, Construction & Operations Technical Committee of Pipeline Research Council International, Inc.*, PRCI Catalogue No. L51927.

ICBO (International Conference of Building Officials) (1997) The Uniform Building Code, 1997 Edition, Whittier, California.

ICC (International Code Council) (2002) International Building Code 2003, Falls Church, Virginia.

Intera Corporation (1991) Geological Map of Sakhalin; Map Compilation and Explanatory Notes, 3 Plates, Scale 1:500,000, 33 p.

Inzhaschita (2004) Engineering findings for pipeline alignment Sakhalin II, landslide process Book 1, Kp 322-362 (old values).

Jolivet, L., T. Kensaku, and M. Fournier (1994) Japan Sea, Opening History and Mechanism: A Synthesis. *Journal of Geophysical Research*, Vol. 99, Number B11, p. 22,237-22,259.

Mohareb, M. E., A. E. Elwi, G. L. Kulak, and D. W. Murray (1994) Deformational Behaviour of Line Pipe. *Structural Engineering Report 202, Department of Civil Engineering*, University of Alberta, Canada.

Nyman, D. J., D. G. Honegger, and P. C. Thenhaus (2003) Considerations for the Design of Buried Natural Gas and Liquid Hydrocarbon Pipeline Fault Crossings. *Proceedings of the 6th U.S. Conference on Lifeline Earthquake Engineering (Advancing Mitigation Technologies and Disaster Response)*, Long Beach, CA, TCLEE, ASCE pp. 744-756.

Oskozbin, L.S., A.A. Poplavsky, and B.N. Zanyukov (1967) Nogliki Earthquake of 2 October 1964", Yuzhno-Sakhalinsk. Sakhal. Complex. *Research Institute of the Academy of Science of USSR*, 86 p.

RSIS (Rosstroiiizyskaniya) (1998) Final Report on the Results of Seismic Micro-Regionalization (State Enterprise 'Rosstroiiizyskaniya, 1998) *Report prepared for Sakhalin Energy Investment Company, Ltd.* By RSIS, Yuzhno-Sakhalinsk and Moscow.

Saipem (2003) Sakhalin II Phase 2 Development Project, Offshore Pipelines and Cables, Seismic Design Data *Report prepared for Sakhalin Energy Investment Company, Ltd.*

Sadigh, K., C.-Y. Chang, J.A. Egan, F. Makdisi, and R. R. Youngs (1997) Attenuation Relationships for Shallow Crustal Earthquakes Based on California Strong Motion Data. *Seismological Research Letters*, Vol. 68, p. 180-189.

Scott Wilson (2001) Pipeline Route and Slope Stability Study.

Scott Wilson (2002) Pipeline Route and Slope Stability Study – Phase 2.

Scott Wilson, Starstroi, (2004) Landslide Hazard (Makarov Area) – Kp 339-379 (new): Review of Inzhaschita Report (2003 Surveys).

Scott Wilson (2005) Sakhalin 2 Phase 2 – Technical Support for Pipeline Route Feasibility and Slope Stability Study: Review Report 01 – Final.

Seno, T. (1995) The Neftegorsk Earthquake as the Intraplate Event: Tectonic Interpretation, in The May 27(28) 1995 Neftegorsk Earthquake", *Informational-Analytical Bulletin of FSSO*, Special Issue, October 1995, R.P. Laverov, ed., p. 135-138.

Seno, T., T. Sakurai, and S. Stein (1996) Can the Okhotsk Plate be Discriminated from the North American Plate?. *Journal of Geophysical Research*, Vol. 101, p. 11,301-11,315.

Shimamoto, T., M. Watanabe, Y. Suzuki, A.I. Kozhurin, M. Strel'tsov, and E. Rogozhn (1996) Surface Faults and Damage Associated with the 1995 Neftegorsk Earthquake. *Journal of the Geological Society of Japan*, Vol. 102, p. 894-907.

Solov'yev, S.L., N.N. Lenov, L.S. Oskorbin, L.F. Volkova, and E.A. Vorob'yeva, (1973) The Moneron Earthquake of 5-6 September 1971. *Doklady Academy of Science, Russia, Earth Science*, Vol. 212, No. 1, p. 3-6.

Stel'tsov, M.I., and Rozhdestvenskii, V.S. (1995) Active Faults of the Kuril-Okhotsk Region, Sakhalin, and the Far East Region, in Seismicity and Seismic Zonation of Northern Eurasia, Moscow: Inst. Fiz. Zemli Ross. Akad. Nauk, p. 387-407.

Starstroi, (2002) Definition Engineering Report (5000-Y-90-01-T-001).

Starstroi (2004) Seismic Hazard Assessment Book 2, Volume 9: Assessment of Active Faults Kinematics. *Sakhalin II Project, Phase 2, EPC Contract H-00244, Onshore Pipelines*, 98 p. Plus Plates.

Starstroi (2004) Engineering Survey: Landslide Areas. Spread 3 and 4 from Kp 339 to Kp 464. Detail Design Phase.

Sylvester (1988) Strike-Slip Faults. *Geological Society of America*, Vol. 100, p. 1666-1703.

URS Corporation (2002) Seismic Hazard Analysis and Development of Seismic Design Spectra for Proposed Onshore Processing Facility, Sakhalin Island, Russia. *Prepared for Shell International Oil B.V.*

Walker, A. C. and K. A. Williams (1995) Strain Based Design of Pipelines. *Proceedings of the 14th International Conference on Offshore Mechanics and Arctic Engineering*, Vol. 5, American Society of Mechanical Engineers, pp. 345-350.

Youd, T.L., C.M. Hansen, and S.F. Bartlett (2002) Revised Multilinear Regression Equations for Prediction of Lateral Spread Displacement, *J. Geotechnical and Geoenvironmental Engineering*, December, vol. 128, no. 12, pp. 1007-1017.

Youd, T.L., and D.M. Perkins, 1978. Mapping of liquefaction induced ground failure potential: American Society of Civil Engineers, *J. Geotechnical Engineering Division*, v. 104, no. GT4, p. 433-446.

APPENDIX 8A

LIST OF LOCATIONS OF SATURATED SAND LAYERS SUSCEPTIBLE TO LIQUEFACTION ALONG THE PIPELINE ROUTE

SEGMENT 1				
ID N.	KP		Length (m)	EGE
	from	to		
1	0.0	4.3	4300	CHAIVO
2	6.0	9.0	3000	
3	10.2	10.3	100	
1	31.20	31.35	150	20
2	32.10	32.40	300	21
3	33.65	33.80	150	20
4	33.95	34.30	350	21
5	37.30	37.45	150	21
6	38.10	38.45	350	21, 23
7	45.70	47.60	1900	21
8	47.85	48.15	300	21
9	49.40	49.70	300	21
10	52.15	52.50	350	21
11	53.80	54.00	200	20, 21
12	54.25	54.60	350	25
13	57.70	58.00	300	21
14	58.50	58.70	200	25
15	58.80	58.90	100	25
16	61.25	61.35	100	25
17	62.00	62.50	500	21
18	63.95	64.30	350	26
19	64.75	64.95	200	23
19	66.10	66.40	300	21/23
20	67.40	67.70	300	21
21	68.50	68.65	150	21
22	68.85	69.00	150	21
23	70.70	70.80	100	21
24	70.95	71.10	150	21
25	72.45	72.60	150	21
26	72.90	73.00	100	21
27	73.25	73.30	50	21
28	73.60	73.70	100	21
29	74.25	74.30	50	21
30	74.40	74.55	150	21
31	75.10	75.30	200	21
32	75.40	75.60	200	22
33	76.75	76.90	150	21
34	77.00	77.30	300	21
35	78.30	78.40	100	21

SEGMENT 1				
36	79.60	79.75	150	21
37	80.60	80.75	150	23
38	81.70	81.90	200	21
39	82.65	82.75	100	21
40	83.05	83.30	250	23
41	84.45	84.75	300	21
42	87.95	88.10	150	21
43	92.60	92.65	50	21
44	96.40	96.55	150	21
45	101.50	101.75	250	21
46	102.05	102.10	50	21
47	106.35	106.90	550	21
48	108.10	108.40	300	21
49	109.40	109.60	200	21
50	111.75	111.85	100	22
51	113.40	113.45	50	21
52	113.90	114.00	100	20
53	116.80	116.90	100	21
54	117.70	117.75	50	21
55	118.10	118.15	50	20
56	120.90	121.40	500	21
57	124.15	124.45	300	23
58	125.50	125.80	300	21
59	136.95	137.05	100	21
60	138.10	138.20	100	21
61	138.30	138.40	100	20
62	138.75	138.90	150	21
63	140.300	140.900	600	21
64	163.400	163.620	220	24
65	163.800	163.950	150	21
66	166.750	166.950	200	24
TOTAL LENGTH (m)			15320	

SEGMENT 2				
ID N.	KP		Length (m)	EGE
	from	to		
67	0.00	0.75	750	23, 25

SEGMENT 3				
ID N.	KP		Length (m)	EGE
	from	to		
68	0.58	0.63	50	23
69	0.75	0.85	100	24
70	6.95	7.05	100	22
71	13.30	13.55	250	23
72	19.60	19.80	200	23
73	20.10	20.30	200	23
74	54.00	54.30	300	23
75	90.10	90.45	350	25
76	91.20	91.50	300	21, 25
77	99.23	99.28	50	27
78	102.28	102.38	100	26
79	107.15	107.25	100	22
80	108.20	108.45	250	22
81	108.92	109.02	100	22
82	109.05	109.15	100	22
83	109.28	109.38	100	22
84	109.55	109.65	100	22
85	111.14	111.19	50	25
86	111.23	111.33	100	25
87	112.50	112.70	200	25
88	113.88	114.45	570	24
89	116.63	116.66	30	23
90	119.50	119.90	400	27-25
91	121.30	121.50	200	21-25
92	122.300	122.550	250	25
93	123.400	123.750	350	21
94	124.10	124.30	200	21
95	124.45	124.70	250	25
96	125.40	125.60	200	25
97	128.85	128.90	50	24
98	129.00	129.30	300	24
99	136.15	136.25	100	25
100	136.90	137.05	150	27
101	142.95	143.20	250	21
102	144.25	144.35	100	25
103	144.60	144.70	100	23

SEGMENT 3				
104	160.20	160.40	200	21
105	160.70	160.80	100	28 (sandy)
106	167.70	167.85	150	27
107	173.95	174.15	200	27
108	220.80	221.50	700	20, 21
109	228.75	229.20	450	
110	251.15	251.40	250	27
111	251.65	251.75	100	28 (sandy)
112	252.60	253.20	600	27
113	276.25	276.70	450	21
114	279.50	280.10	600	21
115	286.00	286.20	200	28 (sandy)
116	324.10	324.30	200	27
117	327.10	327.18	80	22
118	332.30	332.40	100	22
119	334.20	334.40	200	22
120	337.75	337.87	120	22
121	340.65	340.85	200	21
122	398.45	398.65	200	27
123	415.32	415.45	130	27
124	469.85	469.95	100	27
125	474.45	474.49	40	21
126	474.80	475.20	400	22
127	476.55	477.00	450	22
128	480.09	481.08	990	22
129	491.82	491.86	40	27
130	501.65	501.85	200	28 (sandy)
131	506.00	506.05	50	22
132	511.60	511.72	120	21
133	512.45	512.60	150	21
134	512.85	513.10	250	21
135	517.65	517.80	150	21
136	522.60	522.85	250	21
137	531.25	531.40	150	21
138	546.20	546.55	350	28 (sandy)
139	566.00	566.10	100	21
140	586.05	586.35	300	26
TOTAL LENGTH (m)			15920	

APPENDIX 8B

MAKAROV AREA - TRIAL PITTING ESSENTIAL TO CONFIRM GROUND CONDITIONS FOR DESIGN AND CONSTRUCTION (AUG 2005)

KP	Slope Stability Issue	Proposed Action	Alignment Status
343.280	Possible large deep seated landslide	Site walkover, engineering geological mapping and TPs	
343.784	Gully head along ridge line	Trial pitting for foundation level design	
343.920	Pinch point on ridge	Trial pitting for foundation level design	
347.250	Possible solifluction or liquefaction	Foundation level design during construction	RoW prepared
347.600	Landslide	Trial pitting to confirm results of geophysical exploration	No RoW preparation as yet
348.900-349.200	Potential mining subsidence	Trial pits in surface depressions	RoW prepared
350.430	Pinch point on ridge	Trial pitting for foundation level design	
350.700	Landslide	Site walkover, engineering geological mapping and TPs	
351.000-351.300	Potential mining subsidence and narrow spur	Trial pits in surface depressions	
353.380-356.800	Pulka valley re-route	Awaiting proposed design. Trial pitting required wherever landslide deposits on side slopes are encountered	No RoW preparation as yet
359.950	Solifluction/colluvium	Trial pitting	RoW under preparation
360.940	Pinch point on ridge	Trial pitting for foundation level design	RoW prepared
362.225-362.660	Varvarka valley route/reroute	Awaiting proposed design.	No RoW preparation as yet
363.340, 363.610	Landslide/flow deposits	Trial pitting	Pipelines being installed/installed already
364.250-364.800	Pinch points on ridge with failing spoil dumps	Foundation level design during construction	
370.200-370.700	Landslides encroach on alignment from upslope (370.6 area)	Trial pitting	RoW under preparation

KP	Slope Stability Issue	Proposed Action	Alignment Status
	and downslope (370.3 area)		
372.860 area	Landslides on or alongside the RoW	Trial Pitting	RoW under preparation
373.060 area	Flow slides across the RoW	Trial Pitting	RoW under preparation
374.010	Landslide below alignment	Trial Pitting	RoW under preparation
374.300-374.800	Gully and landslide heads adjacent to narrow ridge	Trial pitting	RoW under preparation
374.950	Pinch point on ridge	Trial Pitting	RoW under preparation
376.640-377.070	Deep landslide on original alignment	Trial Pitting	RoW under preparation
377.770-378.650	Narrow ridge, fill material and slope instability	Trial Pitting	RoW under preparation
378.870-380.470	Ridge line with erosion and landslide back scars adjacent	Trial Pitting	No RoW Preparation as yet
381.470-381.620	Narrow ridge, deep failures either side	Trial Pitting	No RoW Preparation as yet
381.725-381.850	Landslides on flanks of spur	Trial Pitting	No RoW Preparation as yet
381.850-382.300	Valley side failure, deep seated, possibly active	Alignment review required	No RoW Preparation as yet
382.310-382.560	Unstable landslide/gully heads.	Careful alignment and trial pitting	No RoW Preparation as yet
382.885-383.000	Possible deep seated valley side failure to west	Local re-routing to avoid	No RoW Preparation as yet
383.170-383.400	Descent and ascent of river valley with flanking instability	Careful alignment selection and trial pitting	No RoW Preparation as yet
384.500 area	Instability on valley flank	Trial Pitting	No RoW Preparation as yet
385.360 area	Instability on valley flanks, either side of river	Trial Pitting	No RoW Preparation as yet
398.200 area	Landslide beneath ridge line	Trial pitting to ensure alignment unaffected	No RoW Preparation as yet
400.700-406.000	Significant landslide hazards in this area	Subject to alignment review	No RoW Preparation as yet
407.550	Landslide on valley flank	Trial Pitting	Pipeline(s) probably installed already
409.050	Landslide heads below alignment on bend	Trial Pitting	Pipeline(s) probably installed already
410.600 area	Landslides crossed by alignment	Trial Pitting	Pipeline(s) probably installed already
417.980	Narrow ridge and gully head	Trial Pitting	Unknown
423.470 area	Ridge line compromised by	Trial Pitting	Oil pipe buried already

KP	Slope Stability Issue	Proposed Action	Alignment Status
	failures either side		
425.825-426.500	Landslide No 1. POC/SEIC approved easterly diversion will require confirmatory GI	Trial Pitting	RoW partially prepared on original alignment
428.000-429.700	Landslides and flow deposits mantle slopes	Alignment selection and GI required to confirm safe location/burial depths	RoW prepared and pipeline installation underway
430.800	Landslide crosses alignment	Trial Pitting	Unknown
431.000	Alignment crosses local landslides	Trial Pitting	Unknown
431.260	Alignment crosses local landslides	Trial Pitting	Unknown
433.000 area	Landslides on valley flank	Trial Pitting	Unknown
434.730-435.250	Narrow ridge with flanking erosion heads	Trial Pitting	Unknown
436.130 area	Gully heads and shallow landslides	Trial Pitting	Unknown
449.500 area	Landslide head and gully head along ridge	Trial Pitting	Unknown
456.300-456.700	Narrow ridge, erosion/landslide scars	Trial Pitting	Unknown

APPENDIX 8C

MAKAROV AREA - DESIGN CONTROL SHEET FOR LEVEL 3 RISK AREAS

DESIGN CONTROL OF LEVEL 3 RISK AREAS

№ по проекту № on the project	№ ОГП по отчету "Инжзащиты" № Geohazard on the report of "Inzachita (*)	Position Местоположение	№ детального чертежа Detailed design №	Послано в СЕИК SENT to SEIC		SEIC comments	Примечание 1 Note 1	Примечание 2 Note 2
				№ сопроводительного письма N.of TRSM	Дата передачи Date of TRSM	Комментарии СЕИК		
1	5	7	8	17	18	19	24	25
340/15	10	Lower part of the North- East and South - West slope of the r.Kormovaya valley	5600-C-90-12-C-9651	H-00264-STY/SEIC/TF/1121	30/06/2005	Not approved Не согласовано SEIC/H-00264/CNST/L/1794	The reroute of fault crossing don't affect the work to prepare in the area 340/15 Перетрассировка на участке разлома №15 не попадает на проектируемый участок	
			5600-C-90-12-D-9651	H-00264-STY/SEIC/TF/1121	30/06/2005			
350/15	28б	Medium part of the r. Pulka valley	5600-C-90-12-C-9652	H-00264-STY/SEIC/TF/1163	15/07/2005	Not approved Не согласовано SEIC/H-00264/CNST/L/1791		
			5600-C-90-12-D-9652	H-00264-STY/SEIC/TF/1163	15/07/2005			
350/16	28в	Medium part of the r. Pulka valley	5600-C-90-12-C-9653	H-00264-STY/SEIC/TF/1163	15/07/2005	Not approved Не согласовано SEIC/H-00264/CNST/L/1791	It is necessary to change ROW boundary Необходимо изменение границы полосы отвода	
			5600-C-90-12-D-9653	H-00264-STY/SEIC/TF/1163	15/07/2005			
350/17	28в	Medium part of the r. Pulka valley	5600-C-90-12-C-9654	H-00264-STY/SEIC/TF/1165	15/07/2005	Not approved Не согласовано SEIC/H-00264/CNST/L/1791	It is necessary to change ROW boundary Необходимо изменение границы полосы отвода	
			5600-C-90-12-D-9654	H-00264-STY/SEIC/TF/1165	15/07/2005			
350/24	31б	Lower part of the right slope of the valley of r. Pulka and river crossing	5600-C-90-12-C-9655	H-00264-STY/SEIC/TF/1233	11/08/2005	Not approved Не согласовано SEIC/H-00264/CNST/L/1791		
			5600-C-90-12-D-9655	H-00264-STY/SEIC/TF/1233	11/08/2005			
360/03	40а	Right-bank slope of the r. Left Sosnovka	5600-C-90-12-C-9656					
			5600-C-90-12-D-9656					
360/04	41	Ridge and right-bank slope of the r.Left Sosnovka valley	5600-C-90-12-C-9657				It is necessary to change ROW boundary Необходимо изменение границы полосы отвода	In the phase of longitudinal profiles agreement on the area km 360,0-361,1 В стадии согласования продольных профилей на участок км 360,0-361,1
			5600-C-90-12-D-9657					
360/05	43	Ridge and right-bank slope of the r. Left Sosnovka valley	5600-C-90-12-C-9658				It is necessary to change ROW boundary Необходимо изменение границы полосы отвода	
			5600-C-90-12-D-9658					
360/15	50а ; 51	r.Varvarka valley	5600-C-90-12-C-9671				Полоса отвода окончательно не определена ROW hasn't been defined finally	Внесен в график 20.07.2005г
			5600-C-90-12-D-9671					
370/28	70	Lower part of the right slope of	5600-C-90-12-C-9659	H-00264-STY/SEIC/TF/1177	20/07/2005	Not approved Не согласовано		

DESIGN CONTROL OF LEVEL 3 RISK AREAS

№ по проекту № on the project	№ ОГП по отчету "Инжзащиты" № Geohazard on the report of "Inzachita (*)	Position Местоположение	№ детального чертежа Detailed design №	Послано в СЕИК SENT to SEIC		SEIC comments	Примечание 1 Note 1	Примечание 2 Note 2
				№ сопроводительного письма N.of TRSM	Дата передачи Date of TRSM	Комментарии СЕИК		
1	5	7	8	17	18	19	24	25
		the r. Lesnaya valley	5600-C-90-12-D-9659	H-00264-STY/SEIC/TF/1177	20/07/2005	SEIC/H-00264/CNST/L/1794		
370/35	736	Top of crest between the r. Smuglyanka and strm. Linek	5600-C-90-12-C-9660	H-00264-STY/SEIC/TF/1181	21/07/2005	Not approved He согласовано	It is necessary to change ROW boundary Необходимо изменение границы полосы отвода	
			5600-C-90-12-D-9660	H-00264-STY/SEIC/TF/1181	21/07/2005	SEIC/H-00264/CNST/L/1794		
380/01	81	Right side of the r. Lazovaya valley	5600-C-90-12-C-9661	H-00264-STY/SEIC/TF/1204	01/08/2005	Not approved He согласовано	It is necessary to change ROW boundary Необходимо изменение границы полосы отвода	
			5600-C-90-12-D-9661	H-00264-STY/SEIC/TF/1204	01/08/2005	SEIC/H-00264/CNST/L/1794		
380/08	86	Medium and lower part of the right slope of the stream (without name)	5600-C-90-12-C-9662					
			5600-C-90-12-D-9662					
400/15	105a	Top of crest between the r. Rudnaya and stream (without name)	5600-C-90-12-C-9663	H-00264-STY/SEIC/TF/1215	03/08/2005		It is necessary to change ROW boundary Необходимо изменение границы полосы отвода	In the phase of longitudinal profiles agreement on the area km 402,5-403,2, В стадии согласования продольных профилей на участок км 402,5-403,2
			5600-C-90-12-D-9663	H-00264-STY/SEIC/TF/1215	03/08/2005			
400/16	107	Top of crest between the r. Rudnaya and stream (without name)	5600-C-90-12-C-9664	H-00264-STY/SEIC/TF/1221	05/08/2005		It is necessary to change ROW boundary Необходимо изменение границы полосы отвода	In the phase of longitudinal profiles agreement on the area km 404,5-405,2 В стадии согласования продольных профилей на участок км 404,5-405,2
			5600-C-90-12-D-9664	H-00264-STY/SEIC/TF/1221	05/08/2005			
400/19	109	Right side of the stream (without name) valley	5600-C-90-12-C-9665	H-00264-STY/SEIC/TF/1264	20/08/2005		It is necessary to change ROW boundary Необходимо изменение границы полосы отвода	
			5600-C-90-12-D-9665	H-00264-STY/SEIC/TF/1264	20/08/2005			
400/31	113a	Top of crest between the r. Vostochnaya and r. Uспенka	5600-C-90-12-C-9666	H-00264-STY/SEIC/TF/1215	03/08/2005		It is necessary to change ROW boundary Необходимо изменение границы полосы отвода	In the phase of longitudinal profiles agreement on the area km 404,5-405,2 В стадии согласования продольных профилей на участок км 404,5-405,2
			5600-C-90-12-D-9666	H-00264-STY/SEIC/TF/1215	03/08/2005			
400/32	114a	Top of crest between the r. Vostochnaya and r. Uспенka	5600-C-90-12-C-9667	H-00264-STY/SEIC/TF/1215	03/08/2005		It is necessary to change ROW boundary Необходимо изменение границы полосы отвода	
			5600-C-90-12-D-9667	H-00264-STY/SEIC/TF/1215	03/08/2005			
400/45	1206	Right slope of the r. Ssora	5600-C-90-12-C-9668				It is necessary to change ROW boundary Необходимо изменение границы полосы отвода	
			5600-C-90-12-D-9668					

SAKHALIN II - MAKAROV AREA KP340 - 464

file ref: EIA Report Level p Risks
taken from AT update 25 Aug '05

DESIGN CONTROL OF LEVEL 3 RISK AREAS

№ по проекту № on the project	№ ОГП по отчету "Инжзащиты" № Geohazard on the report of "Inzachita (*)	Position Местоположение	№ детального чертежа Detailed design №	Послано в СЕИК SENT to SEIC		SEIC comments	Примечание 1 Note 1	Примечание 2 Note 2
				N сопроводительного письма N.of TRSM	Дата передачи Date of TRSM	Комментарии СЕИК		
1	5	7	8	17	18	19	24	25
420/20	1256	Slope to the r.Mostovaya valley	5600-C-90-12-C-9669				It is necessary to change ROW boundary Необходимо изменение границы полосы отвода	
			5600-C-90-12-D-9669					
420/30	128	Slope foot of the mountain ridge Zhdanko	5600-C-90-12-C-9670					Final determination of the route centerline is necessary on the area km 429,0-429,5 Необходимо окончательное определение оси трассы на
			5600-C-90-12-D-9670					
426/3		Landslide 1 area	5600-C-90-12-C-####					
			5600-C-90-12-D-####					
428/5		Landslide 2 Area	5600-C-90-12-C-####					
			5600-C-90-12-D-####					
455/0			5600-C-90-12-C-####					
			5600-C-90-12-D-####					

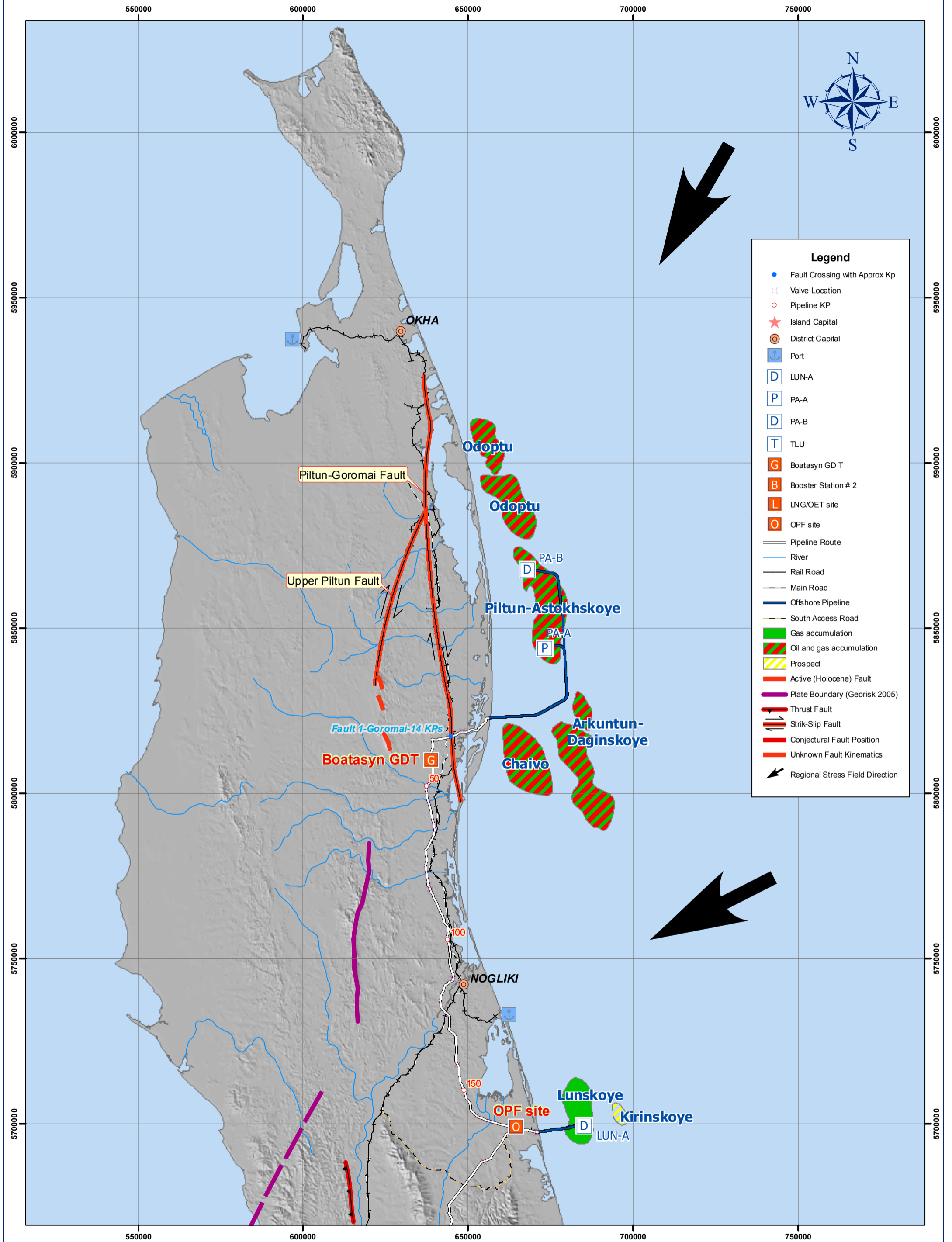

Legend

- Fault Crossing with Approx Kp
- ✕ Valve Location
- Pipeline KP
- ★ Island Capital
- ⊙ District Capital
- ⚓ Port
- D LUN-A
- P PA-A
- D PA-B
- T TLU
- G Boatasyn GD T
- B Booster Station # 2
- L LNG/OET site
- O OPF site
- Pipeline Route
- River
- Rail Road
- Main Road
- Offshore Pipeline
- South Access Road
- Gas accumulation
- Oil and gas accumulation
- ▨ Prospect
- Active (Holocene) Fault
- Plate Boundary (Georisk 2005)
- Thrust Fault
- Strik-Slip Fault
- Conjectural Fault Position
- Unknown Fault Kinematics
- ↖ Regional Stress Field Direction

SEIC DATUM DEFINITION

Sakhalin Energy
 Geomatics
 Group

Horizontal : WGS 84
 Vertical : Baltic 77
 Units : Meters
 Projection : UTM 54 N
 Imagery : xxxxx
 Resolution : xx m



Sakhalin Island Relief Map

Sakhalin 2 Project Facilities with Tectonic Fault Locations

Nominal Scale: 1:1,000,000 @ A3 paper size
 Kilometers

0 5 10 20 30 40 50

Author: Kostyanets, Elena	Creation Date: 16 November 2005
SE Doc No:	GIS File Ref: ys_01157_p2_01

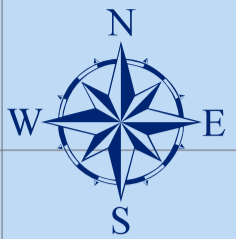
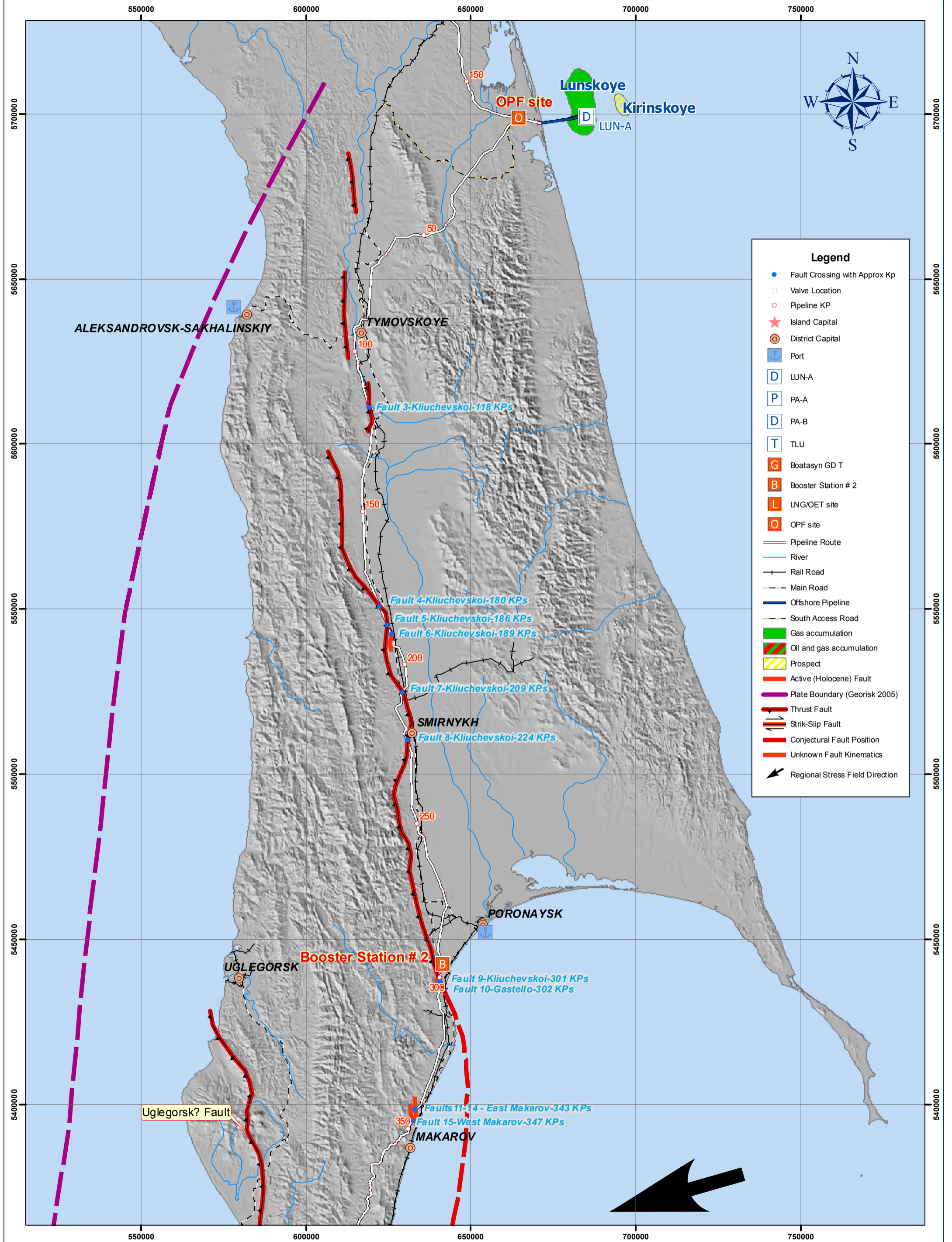

Legend	
●	Fault Crossing with Approx Kp
✕	Valve Location
○	Pipeline KP
★	Island Capital
⊙	District Capital
⚓	Port
D	LUN-A
P	PA-A
D	PA-B
T	TLU
G	Boatasyn GD T
B	Booster Station # 2
L	LNG/OET site
O	OPF site
	Pipeline Route
	River
	Rail Road
	Main Road
	Offshore Pipeline
	South Access Road
	Gas accumulation
	Oil and gas accumulation
	Prospect
	Active (Holocene) Fault
	Plate Boundary (Georisk 2005)
	Thrust Fault
	Strik-Slip Fault
	Conjectural Fault Position
	Unknown Fault Kinematics
	Regional Stress Field Direction

SEIC DATUM DEFINITION
 Horizontal : WGS 84
 Vertical : Baltic 77
 Units : Meters
 Projection : UTM 54 N
 Imagery : xxxxx
 Resolution : xx m



Sakhalin Island Relief Map
Sakhalin 2 Project Facilities with Tectonic Fault Locations
 Nominal Scale: 1:1,000,000 @ A3 paper size
 Kilometers
 0 5 10 20 30 40 50

Author: Kostyanets, Elena	Creation Date: 16 November 2005
SE Doc No:	GIS File Ref: ys_01157_p2_02

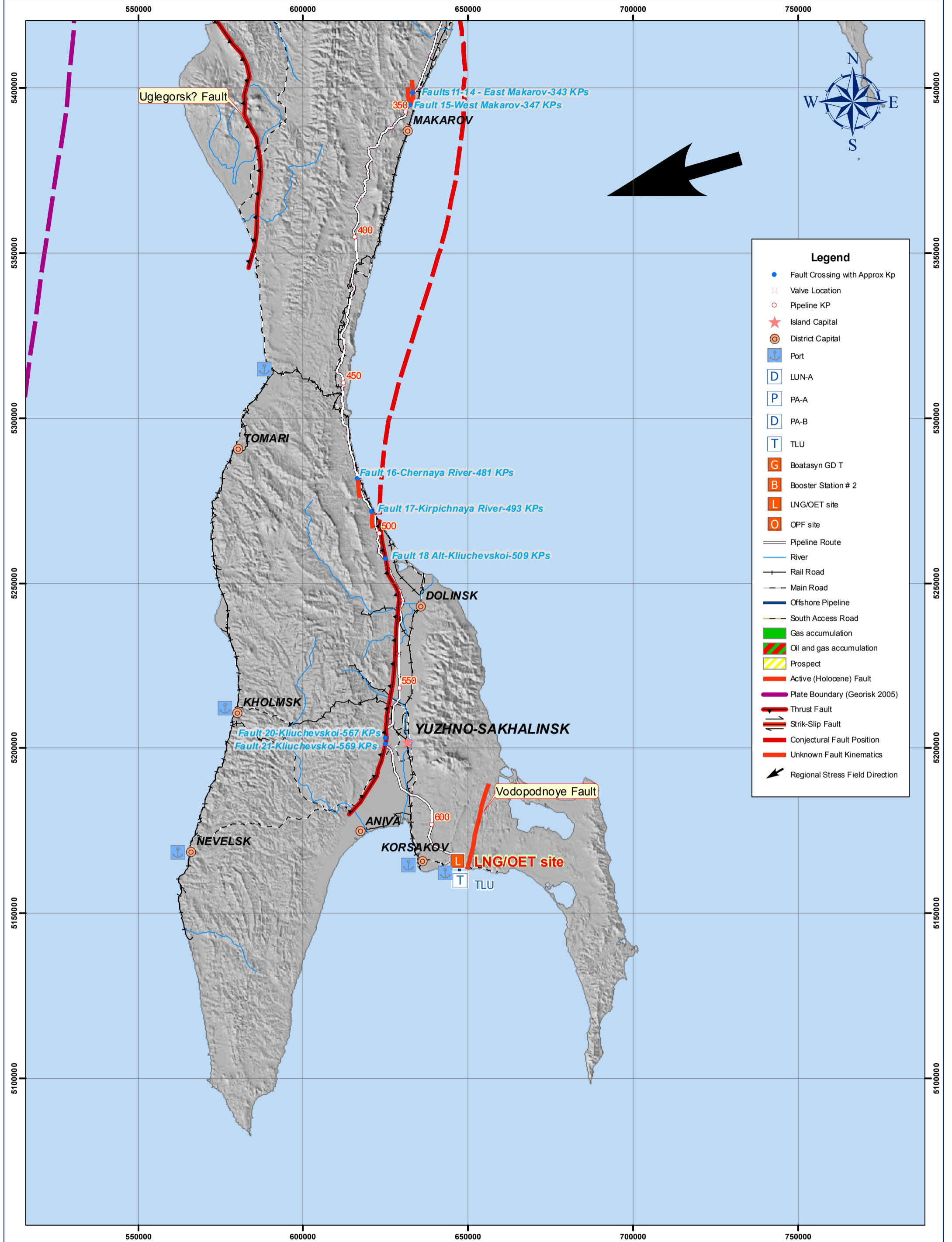

Legend

- Fault Crossing with Approx Kp
- ⊗ Valve Location
- Pipeline KP
- ★ Island Capital
- ⊙ District Capital
- ⚓ Port
- D LUN-A
- P PA-A
- D PA-B
- T TLU
- G Boatasyn GD T
- B Booster Station # 2
- L LNG/OET site
- O OPF site
- Pipeline Route
- River
- Rail Road
- Main Road
- Offshore Pipeline
- South Access Road
- Gas accumulation
- Oil and gas accumulation
- ▨ Prospect
- Active (Holocene) Fault
- Plate Boundary (Georisk 2005)
- Thrust Fault
- Strik-Slip Fault
- Conjectural Fault Position
- Unknown Fault Kinematics
- ↖ Regional Stress Field Direction

SEIC DATUM DEFINITION

Sakhalin Energy
 Geomatics
 Group

Horizontal : WGS 84
 Vertical : Baltic 77
 Units : Meters
 Projection : UTM 54 N
 Imagery : xxxxx
 Resolution : xx m



Sakhalin Island Relief Map

Sakhalin 2 Project Facilities with Tectonic Fault Locations

Nominal Scale: 1:1,000,000 @ A3 paper size
 Kilometers

Author: Kostyanets, Elena	Creation Date: 16 November 2005
SE Doc No:	GIS File Ref: ys_01157_p2_03

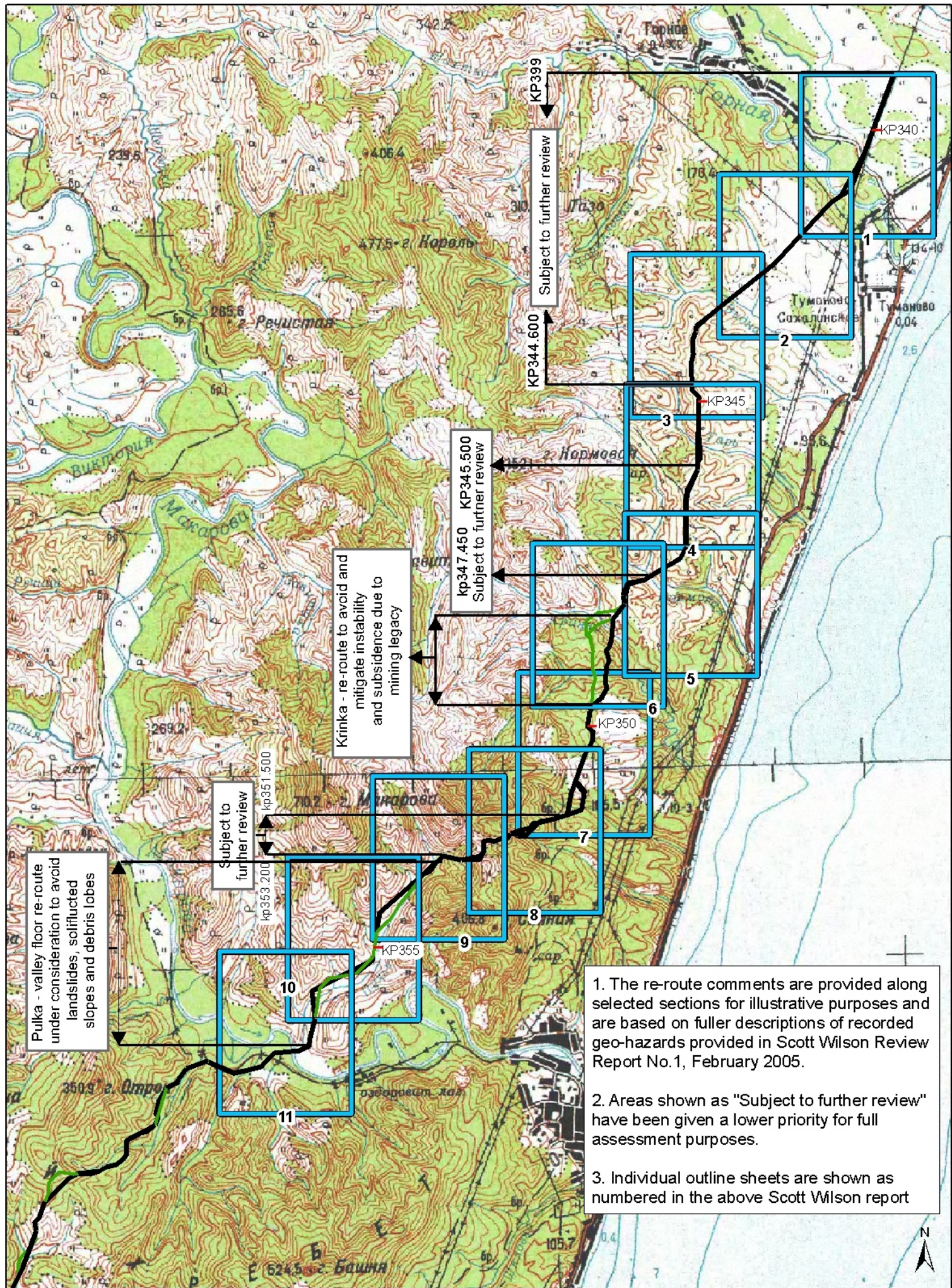

Pulka - valley floor re-route under consideration to avoid landslides, scilicited slopes and debris lobes

Subject to further review

Krinka - re-route to avoid and mitigate instability and subsidence due to mining legacy

kp347.450 KP345.500 Subject to further review

KP344.600 Subject to further review

1. The re-route comments are provided along selected sections for illustrative purposes and are based on fuller descriptions of recorded geo-hazards provided in Scott Wilson Review Report No.1, February 2005.

2. Areas shown as "Subject to further review" have been given a lower priority for full assessment purposes.

3. Individual outline sheets are shown as numbered in the above Scott Wilson report

Drawn By: TH
Date: 06/05/2005
Scale: 1:65000

Figure 1:
Sakhalin 2 Phase II - Environmental Impact Assessment
Makarow Mountain Section
Geohazards - Illustrative Areas of Mass Wasting (Slope Movement) And Ground Instability

Layer
 — Original Route
 — Re-route (agreed or under consideration)
 — Outline Sheets



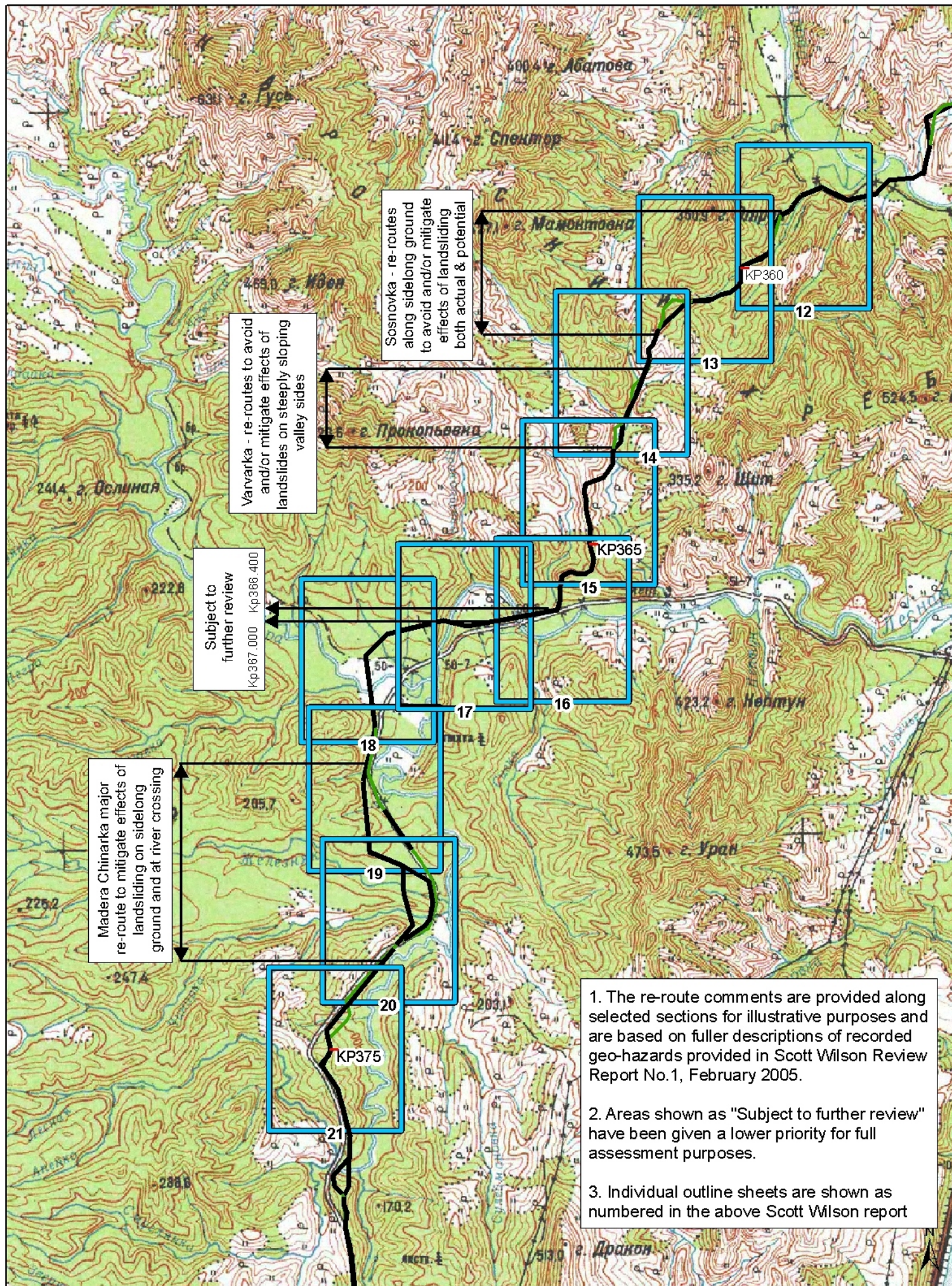

Drawn By: TH
 Date: 06/05/2005
 Scale: 1:55000

Figure 2:
 Sakhalin 2 Phase II - Environmental Impact Assessment
 Makarow Mountain Section
 Geohazards - Illustrative Areas of Mass Wasting (Slope Movement) And Ground Instability

Layer
 Original Route
 Outline Sheets
 Re-route (agreed or under consideration)



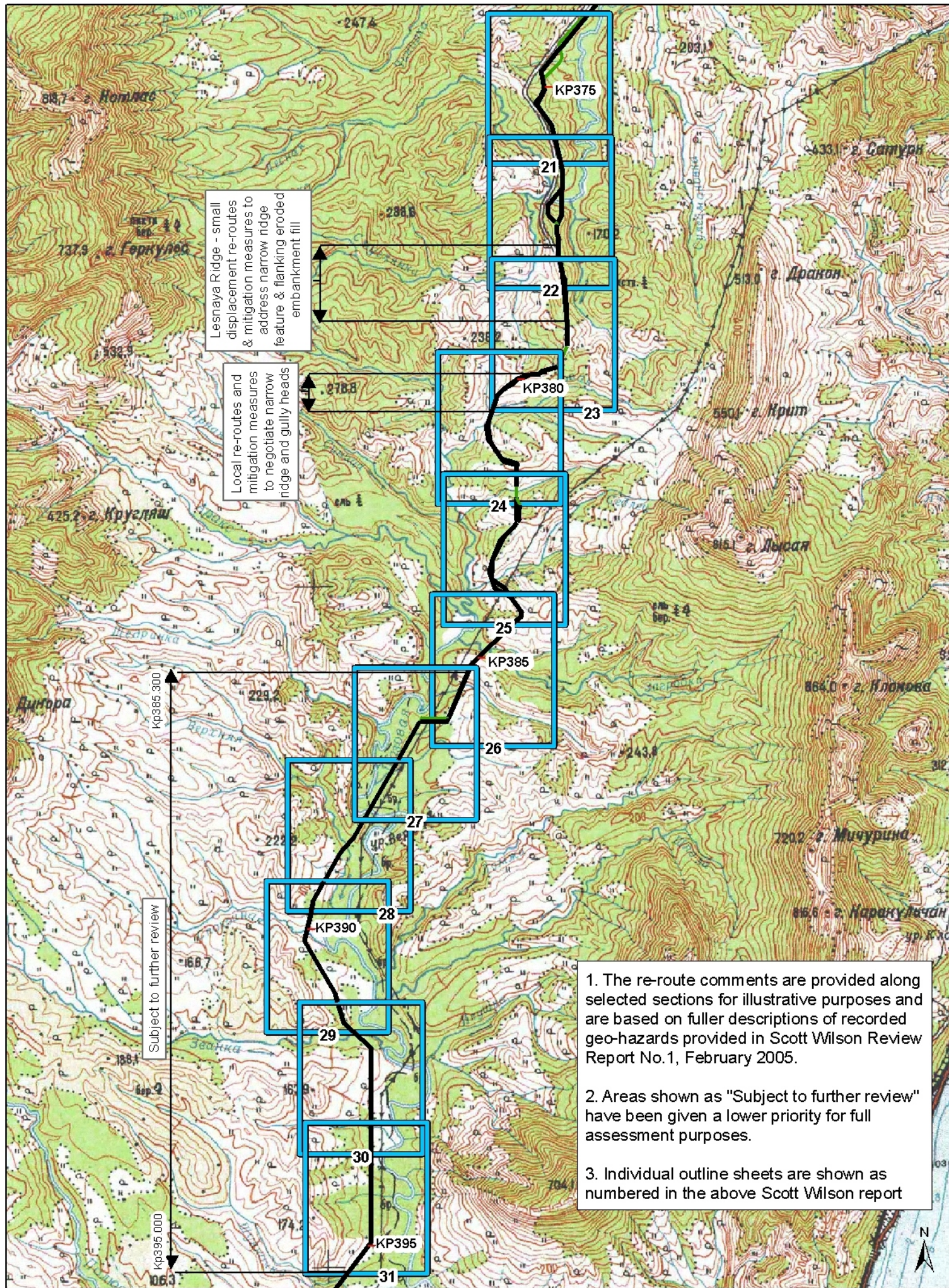

Lesnaya Ridge - small displacement re-routes & mitigation measures to address narrow ridge feature & flanking eroded embankment fill

Local re-routes and mitigation measures to negotiate narrow ridge and gully heads

Subject to further review

1. The re-route comments are provided along selected sections for illustrative purposes and are based on fuller descriptions of recorded geo-hazards provided in Scott Wilson Review Report No.1, February 2005.
2. Areas shown as "Subject to further review" have been given a lower priority for full assessment purposes.
3. Individual outline sheets are shown as numbered in the above Scott Wilson report

Drawn By: TH
Date: 06/05/2005
Scale: 1:70000

Figure 3:
Sakhalin 2 Phase II - Environmental Impact Assessment
Makarow Mountain Section
Geohazards - Illustrative Areas of Mass Wasting (Slope Movement) And Ground Instability

Layer	Description
	Original Route
	Outline Sheets
	Re-route (agreed or under consideration)



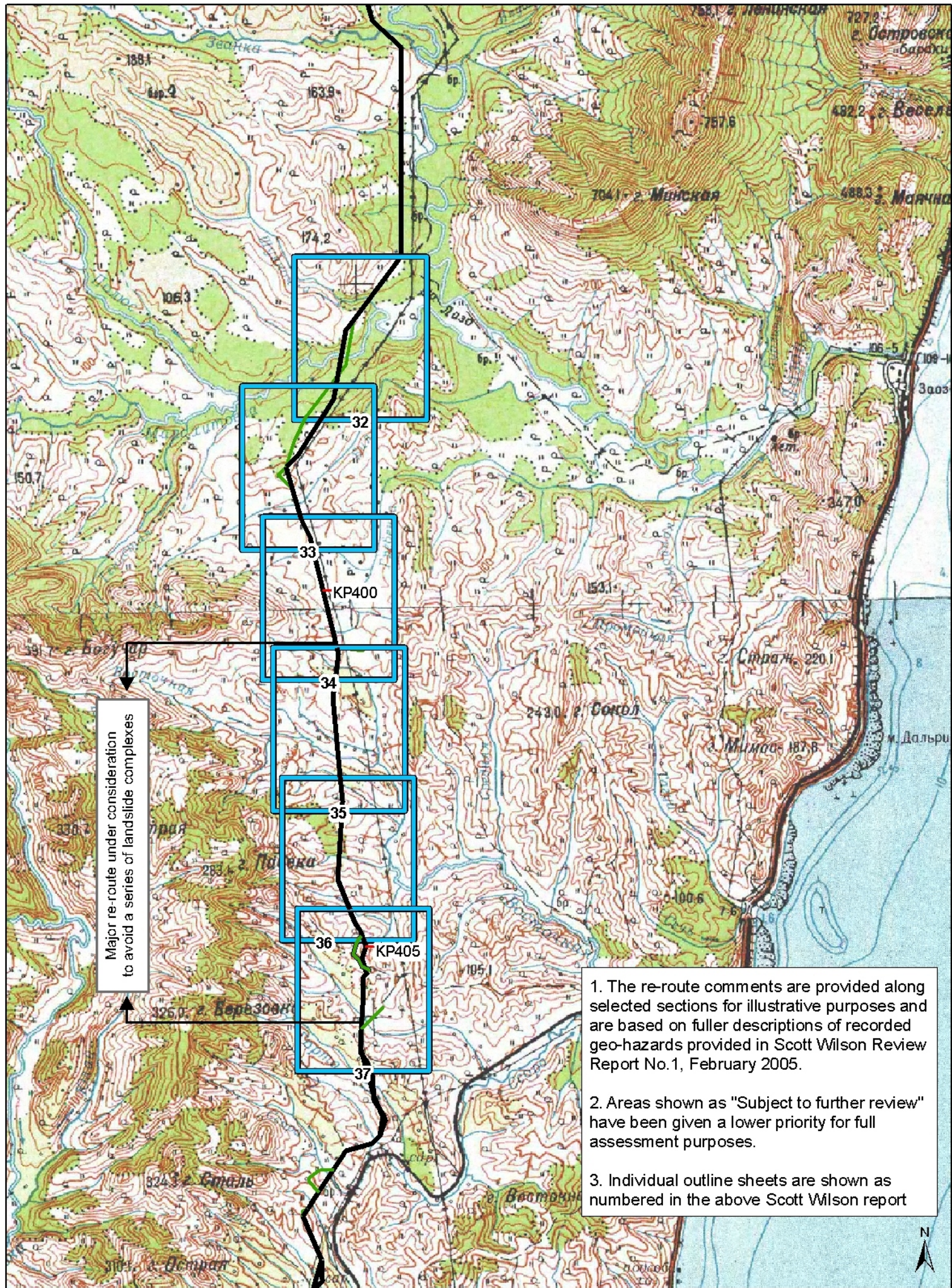



Major re-route under consideration to avoid a series of landslide complexes

1. The re-route comments are provided along selected sections for illustrative purposes and are based on fuller descriptions of recorded geo-hazards provided in Scott Wilson Review Report No.1, February 2005.
2. Areas shown as "Subject to further review" have been given a lower priority for full assessment purposes.
3. Individual outline sheets are shown as numbered in the above Scott Wilson report

Drawn By: TH
Date: 06/05/2005
Scale: 1:65000

Figure 4:
Sakhalin 2 Phase II - Environmental Impact Assessment
Makarow Mountain Section
Geohazards - Illustrative Areas of Mass Wasting (Slope Movement) And Ground Instability

Layer	Description
	Original Route
	Outline Sheets
	Re-route (agreed or under consideration)



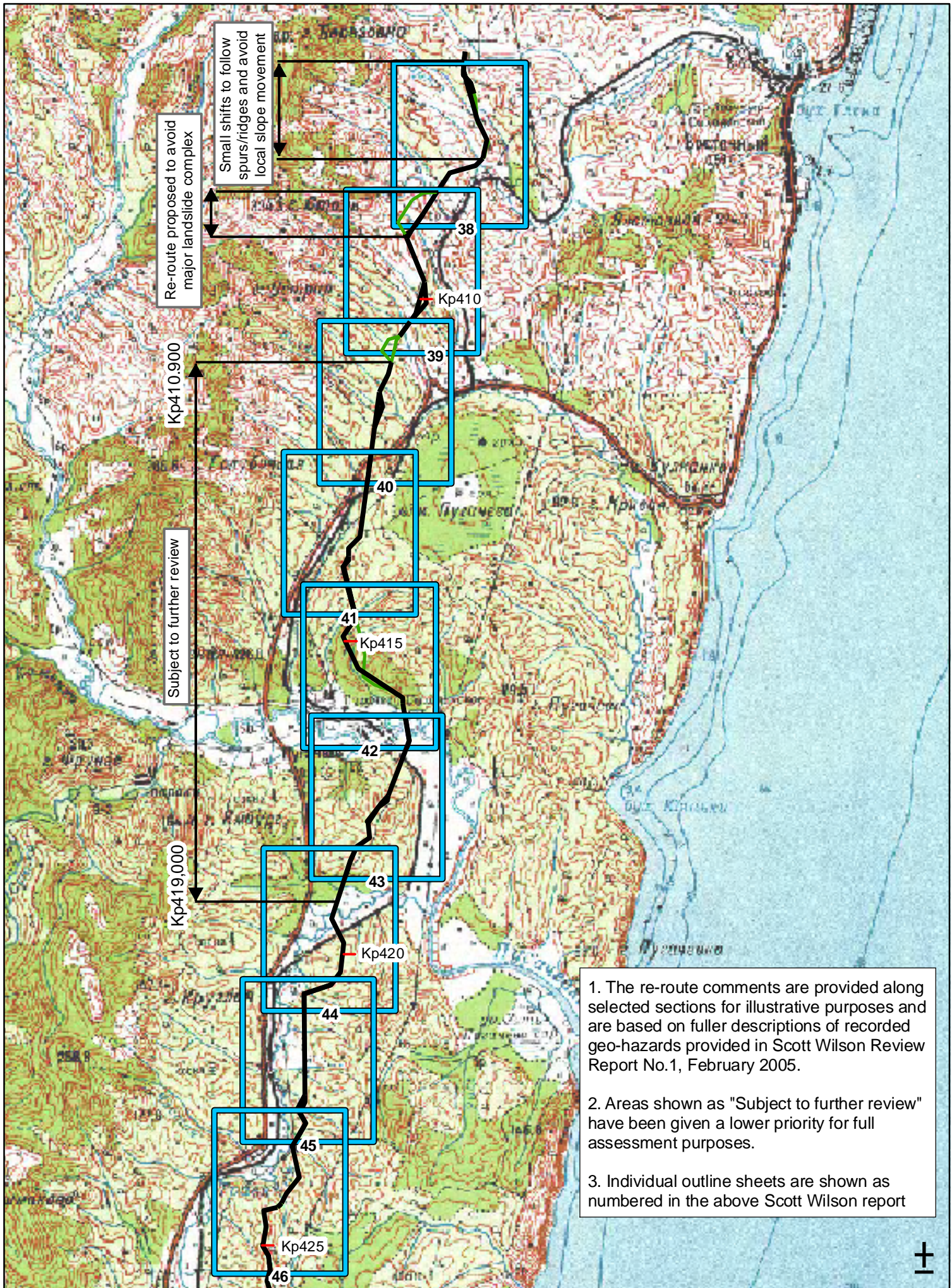

Drawn By: TH
Date: 06/06/2005
Scale: 1:65000

Figure 5:
Sakhalin 2 Phase II - Environmental Impact Assessment
Makarov Mountain Section
Geohazards - Illustrative Areas of Mass Wasting (Slope Movement) And Ground Instability

Layer

- Original Route
- Re-route (agreed or under consideration)
- Outline Sheets



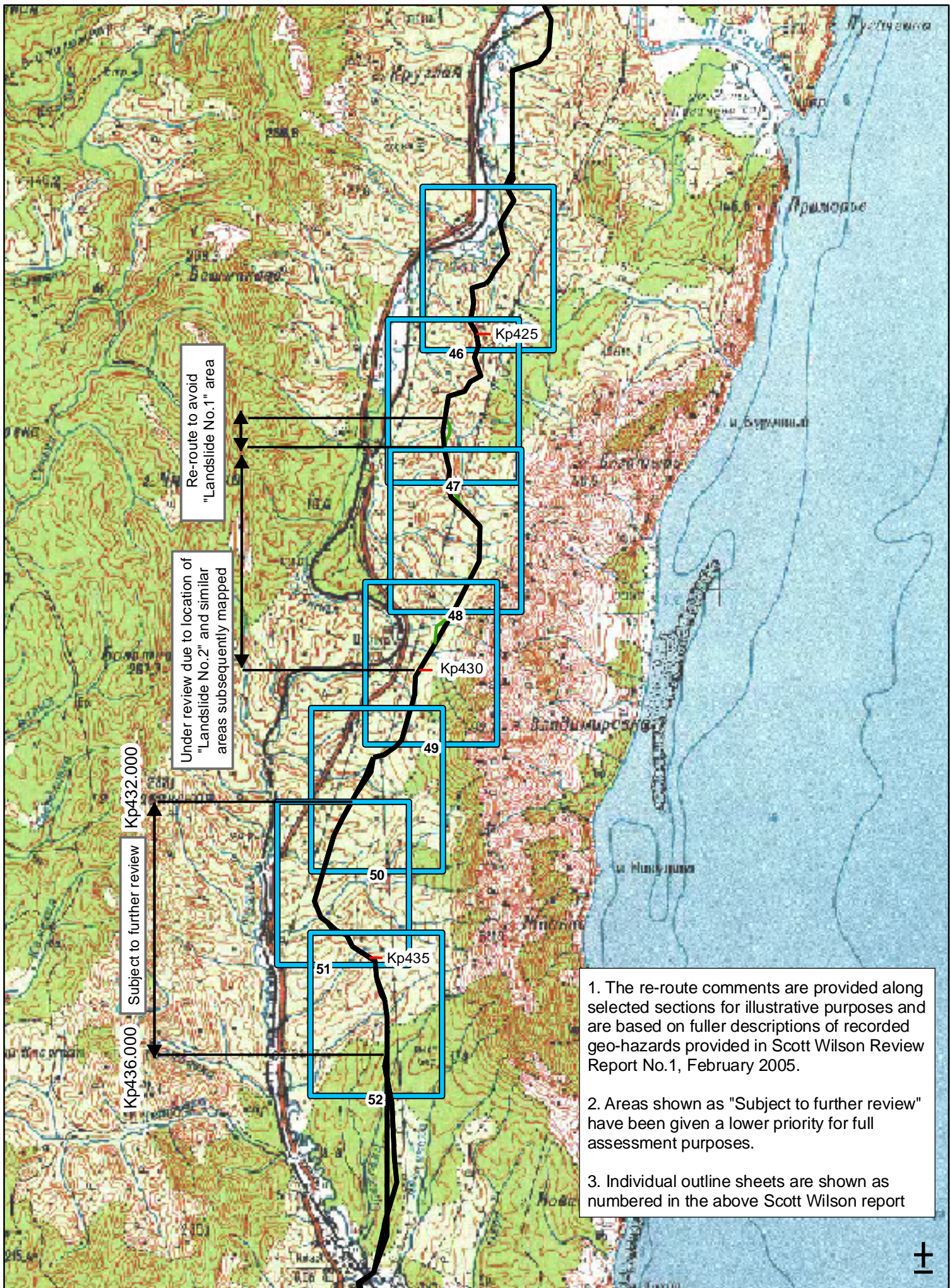

1. The re-route comments are provided along selected sections for illustrative purposes and are based on fuller descriptions of recorded geo-hazards provided in Scott Wilson Review Report No.1, February 2005.
2. Areas shown as "Subject to further review" have been given a lower priority for full assessment purposes.
3. Individual outline sheets are shown as numbered in the above Scott Wilson report

Drawn By: TH
 Date: 06/06/2005
 Scale: 1:65000

Figure 6:
 Sakhalin 2 Phase II - Environmental Impact Assessment
 Makarov Mountain Section
 Geohazards - Illustrative Areas of Mass Wasting (Slope Movement) And Ground Instability

Layer
 ■ Original Route
 ■ Re-route (agreed or under consideration)
 ■ Outline Sheets



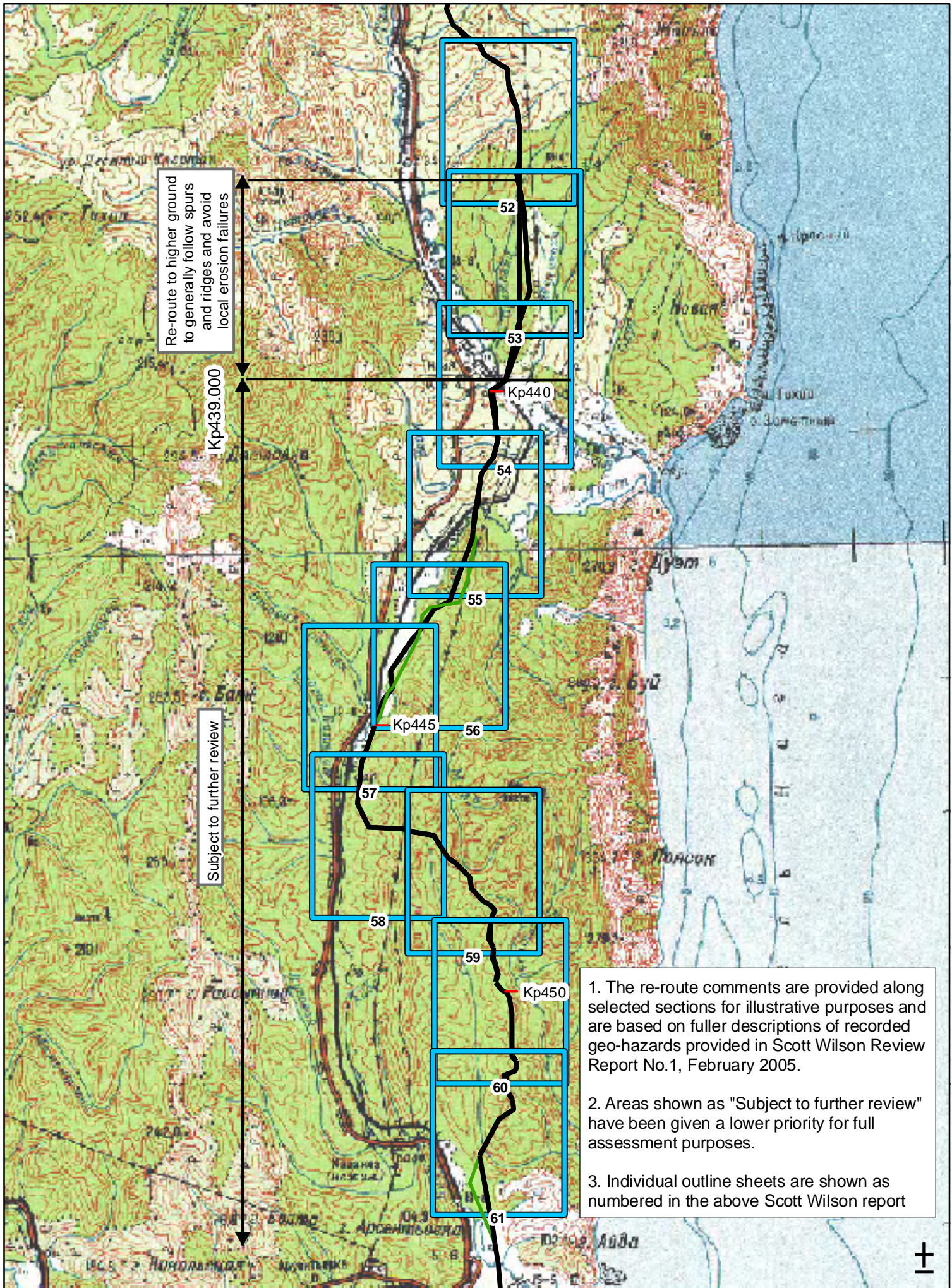

Drawn By: TH
Date: 06/06/2005
Scale: 1:65000

Figure 7:
Sakhalin 2 Phase II - Environmental Impact Assessment
Makarov Mountain Section
Geohazards - Illustrative Areas of Mass Wasting (Slope Movement) And Ground Instability

Layer

- Original Route
- Outline Sheets
- Re-route (agreed or under consideration)



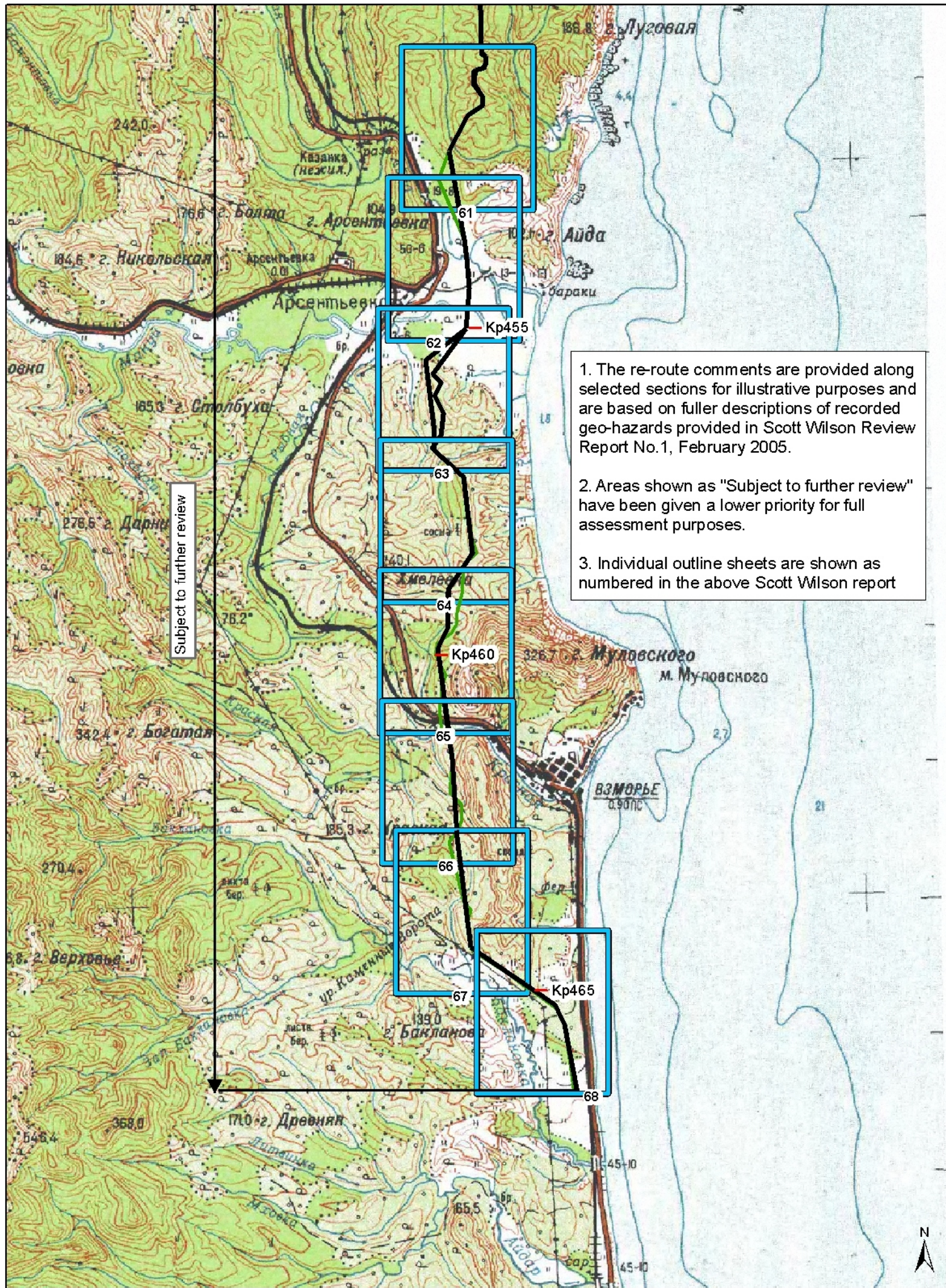

Drawn By: TH
 Date: 11/05/2005
 Scale: 1:65000

Figure 8:
 Sakhalin 2 Phase II - Environmental Impact Assessment
 Makarow Mountain Section
 Geohazards - Illustrative Areas of Mass Wasting (Slope Movement) And Ground Instability

